



**DON'T FORGET**

These instructions can be found in color and expandable at QA1.net

Technical Support Line: (952) 985-5675 Email: sales@QA1.net

**INSTALLATION INSTRUCTIONS**

QA1 P/N Rx21-000 thru Rx21-250 (SWB – Short Wheel Base)  
Rx22-000 thru Rx22-250 (LWB – Long Wheel Base)  
'73-'79 F100, '75-'79 F150 Rear Coil-over Conversion System

**TOOLS AND SUPPLIES REQUIRED**

- Floor Jack
- Two (2) Jack Stands
- SAE Drill Bit Set
- SAE Wrench Set
- Ratchet & SAE Socket Set
- Torque Wrench
- Grinder or Air Chisel
- Anti-seize

**PRE INSTALLATION NOTES:**

This suspension will only work with axles with factory offset 9" pinion and not work with aluminum 3<sup>rd</sup> members.

As with any notched frame, installation of this system will reduce the load carrying capability of the vehicle.

The included hardware kit is also used on other suspension applications. Extra hardware after the installation is complete should be expected.

The auxiliary fuel tank on the driver side (if equipped) will need to be removed to install this suspension.

This rear suspension system can be installed without removing the bed although removing the bed is recommended.

**INSTALLATION:**

1. Place the truck securely on jack stands just forward of the front leaf spring mount to allow enough room for installation. If using a lift, place the rear arms just forward of the front leaf spring mount on the frame.
2. Remove the drive shaft. Brake lines, fuel line, and wiring can be moved around during install.
3. Remove the brake line junction from the rear axle. Unbolt the leaf springs from the leaf spring mounts and remove the leaf springs and the axle.
4. Slot and remove the rivets holding the front leaf spring hanger to the frame and discard the hanger. The three rivets found behind the front leaf mount that hold a frame crossmember **DO NOT NEED TO BE REMOVED. (Figure 1)**

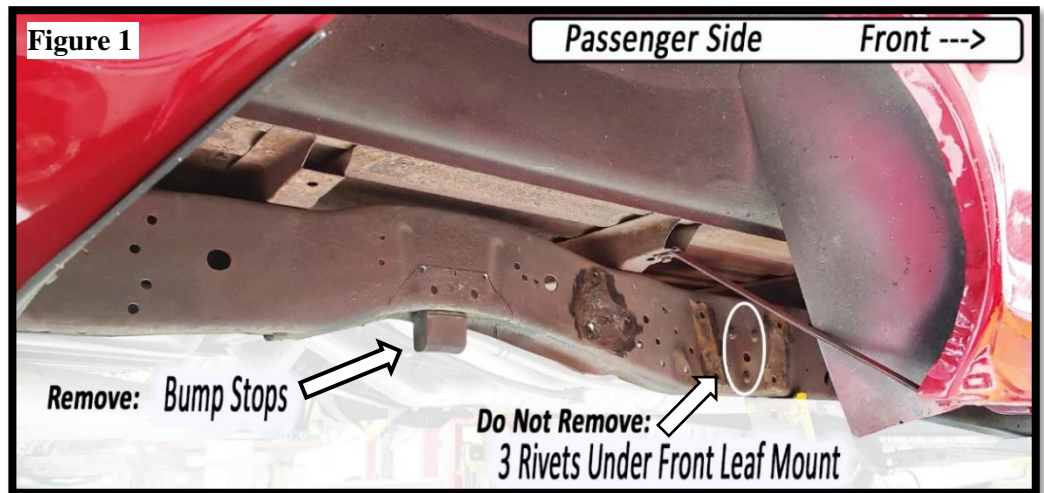

5. **REAR LEAF HANGERS**- The long bed rear leaf spring hanger can optionally be removed but will not interfere with the installation. Rear leaf hangers on **short box trucks** are part of the bumper mount and do not need to be removed to complete the installation.)

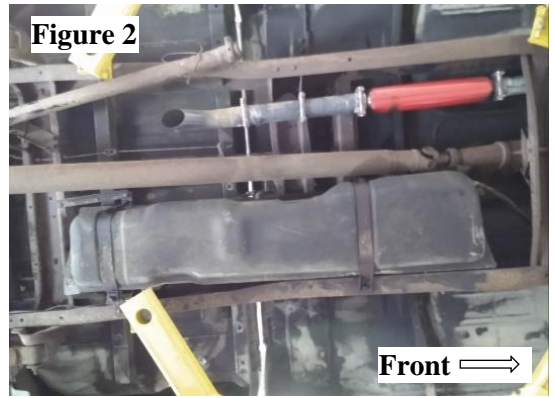

**LONG BOX TRUCKS ONLY**- Remove the auxiliary fuel tank (if equipped) from the driver side frame rail. This fuel tank cannot be used with this suspension. (Figure 2)

6. Remove the driver and passenger side bump stops from the frame rails. (Figure 3)
7. Remove the rivets from the upper shock mounts and discard them. (Figure 4)

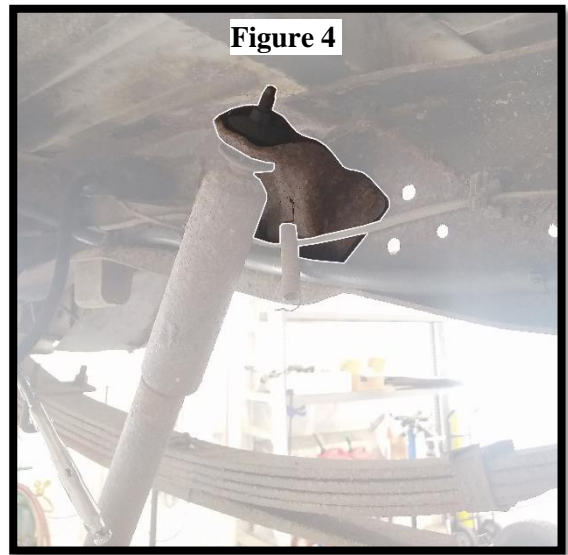
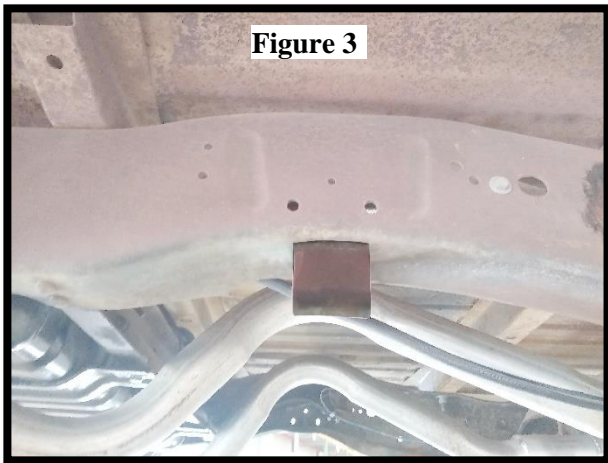

8. A section of the lower frame rail on both the driver and passenger side curls downward. Mark and cut the complete downward curling portion from the frame. (Figure 5) After cutting the curled section and installing the notch your frame rail will look like (Figure 6).



Figure 6



9. Line up the two existing frame holes with the two holes in the notch template that is included with your suspension system. The lower portion of the template will fold under the frame rail. Mark and cut the notch into the frame. This template is symmetrical and can be used on both sides of the truck. **(Figure 7)**



**Figure 7**

10. Clean the frame of dirt, rust and under coating to allow the QA1 notch bracket to fit tightly to the frame. Paint the frame rails as desired.

11. Identify the driver (left side) and passenger (right side) frame notch brackets. **(Figure 8)**

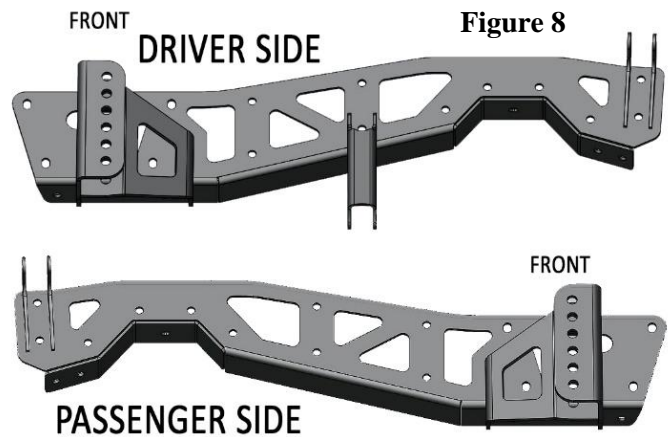

**Figure 8**

12. Fit the notch bracket to frame using the five existing chassis holes pictured below **(Figure 9)** and secure with 7/16" x 1.25" hardware. **The use of clamps to draw the bracket tight to the frame will be helpful before drilling the remaining notch bracket holes to 7/16".**

**INSTALL NOTE:**

This hardware kit will include extra hardware that will not be used for the installation.

1st Description	2nd Description	Qty.
BOLT, 7/16-14 X 1.25"	GRADE 5, CLEAR ZINC	48
WASHER, SAE, 7/16	GRADE 5, CLEAR ZINC	96
NUT, NYLOCK, 7/16-14	GRADE 5, CLEAR ZINC	48

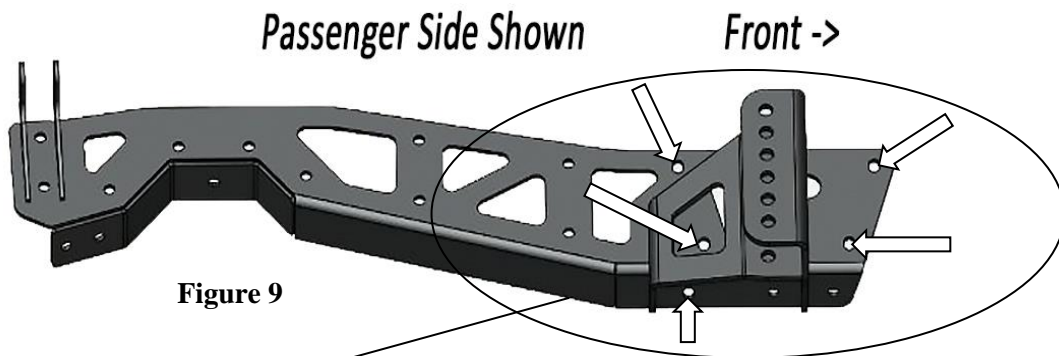

**Figure 9**

**WILL MATCH EXISTING HOLES IN THE FRAME**

13. With the notch bracket drawn in tight to the frame, drill the remaining notch bracket holes using a 7/16" drill bit.

**NOTE:**

Two inner frame brackets share mounting holes with the notch bracket. The bracket for the inner driver side will mount the rear sway bar end link (if installing the 52863 rear sway bar) and the passenger side bracket will mount the passenger side watts linkage and the sway bar end link. The passenger side inner frame bracket will need one upper hole drilled that is not shared with the notch bracket. This hole is easiest to mark and drill before the notch bracket is final installed but is shown being drilled with the notch bracket in place. Install the passenger side bracket when fastening the shared holes of the notch bracket, and the driver side bracket if installing the QA1 rear sway bar. Driver side sway bar bracket will be included within the sway bar packaging. (Figure 10)

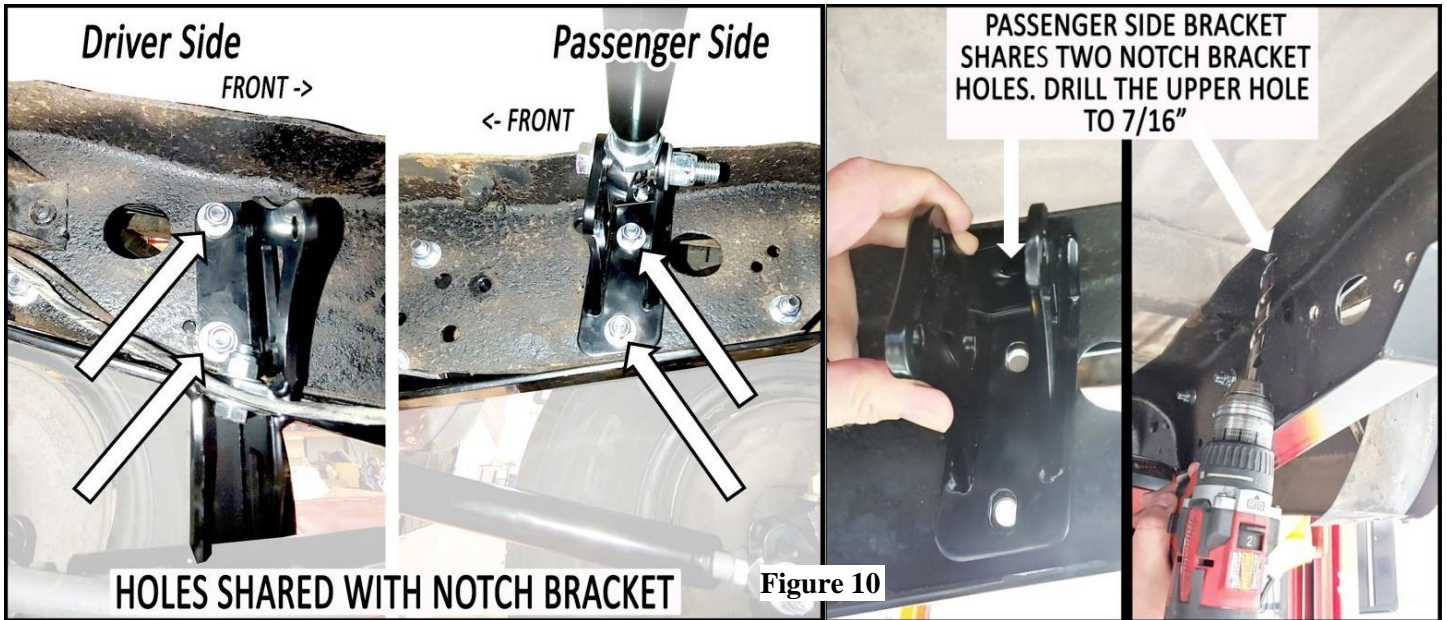

14. Secure all notch bracket holes to the frame by evenly tighten all 7/16" hardware. Torque all to 49 lb. ft.

15. Install the pancake style bump stops onto both sides of the notch bracket. (Figure 11)

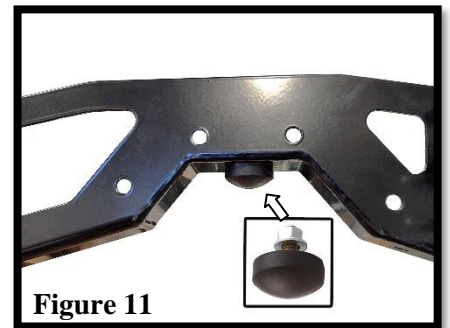

**TRAILING ARMS-**

16. Install a (LH) jam nut (#3) on the (LH) threaded rod end (#4), then apply anti-seize to the threads before fully threading the rod end into the trailing arm.

17. Insert the bushing halves into the fixed bushing end and insert the metal sleeve through the center.

18. With a jam nut threaded onto the bushing end, thread the fixed bushing end into trailing arm as far as possible.

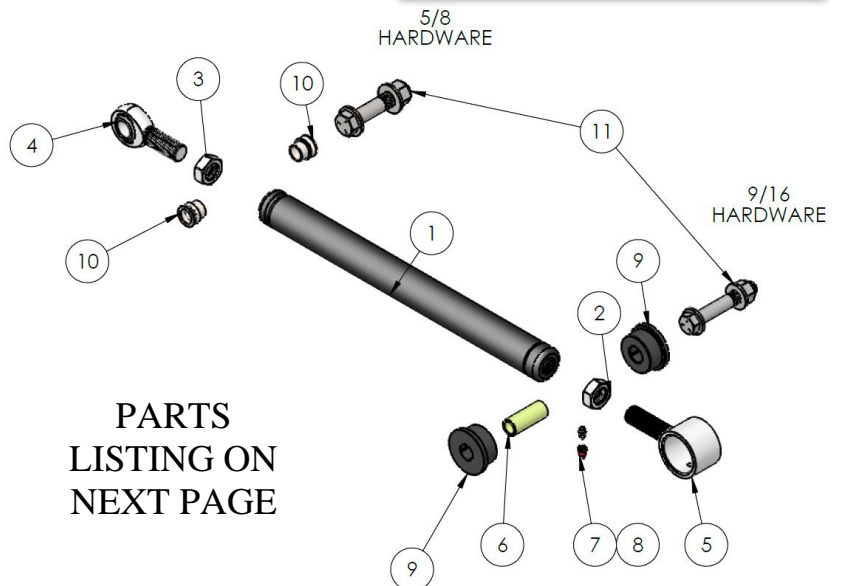



BALLOON #	ITEM #	DESCRIPTION	QTY.
1	9037-729	WELDMENT, TRAILING ARM	2
2	JNR12S	NUT, JAM 3/4-16 RH	2
3	JNL12S	NUT, JAM 3/4-16 LH	2
4	XML12	ROD END (X) ENDURA ALLOY HT	2
5	7039-157	Panhard Rod Asm., Short	2
6	9033-317	Sleeve, .56" ID X .75" OD X 1.88"	2
7	9023-116	CAP. GREASE ZERK	2
8	9023-119	GREASE ZERK, 1/4-28	2
9	9032-169	Bushing, Energy 2042G	4
10	SG12-106	High Misalignment Spacer, SS	4
11	7039-230	HARDWARE KIT, TRAILING ARM	1

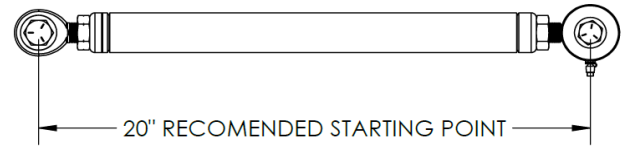

19. With an even amount of thread engagement for both rod ends, set the center-to-center length of the trailing arms to 20" and tighten the jam nuts to the trailing arms.
20. Install the bushing end of the trailing arm into third hole from the top of the notch bracket using 9/16" x 3.5 hardware from the Trailing Arm Hardware Kit (p/n 7039-230). **(Figure 12)** Final torque of 85 lb. ft. should be applied only with the truck at final ride height. Changing the instant center by raising or lowering the trailing arm on this bracket can be adjusted after final ride height is determined. The trailing arm should be parallel to the ground once the final ride height is set.

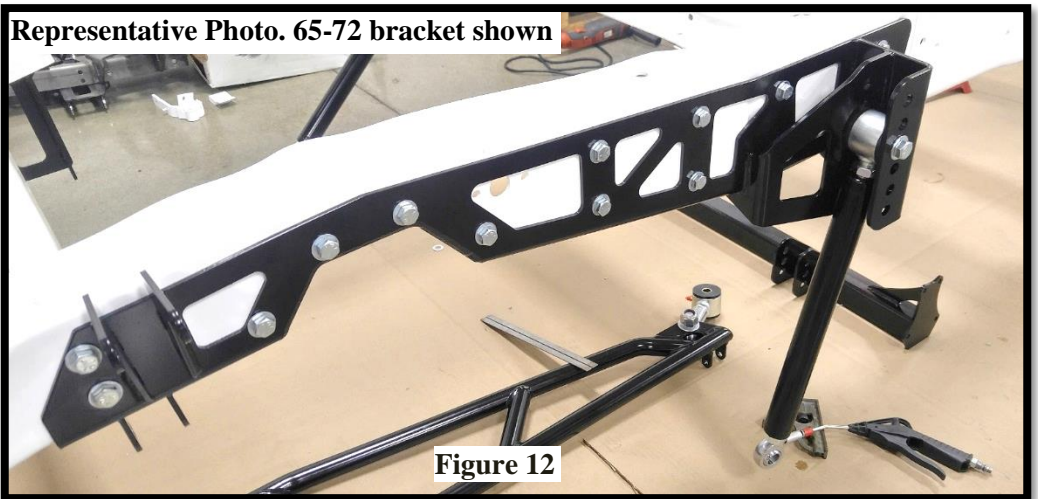

HARDWARE KIT #7039-230	
Description	Qty.
BOLT, 9/16-12 X 3.5"	2
NUT, NYLOCK, 9/16-12	2
WASHER, 9/16, SAE	4
BOLT, 5/8-11 X 3.5"	2
NUT, NYLOCK, 5/8-11	2
WASHER, 5/8, SAE	4

21. Moving to the rear axle you will need to prep the leaf spring perches to mount the QA1 axle plates. Place the QA1 axle plates on top of the axle leaf spring perch. **(Figure 13)** Mark the openings and grind out the leaf spring perches. **(Figure 14 & 15)**

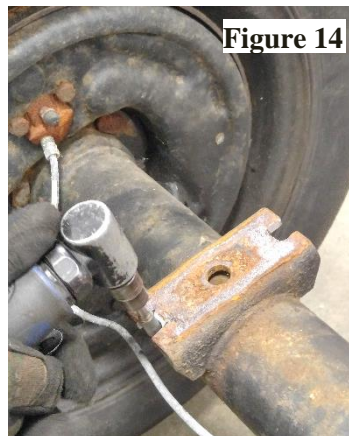

22. Install left and right axle mount bracket onto axle using 5/8" x 5.5" bolts with one 5/8" washer under the 5/8" nylock nut from the Axle Mount Hardware Kit (p/n 7039-235). Torque to 90 lb. ft.
23. Install the left and right shock mount onto each axle mount using 5/8" x 5.5" hardware. **(Figure 16)** Torque to 90 lb. ft. (1/2" hardware will be used to install the coil-over shocks to the "L" brackets)
24. Install the left and right specific "L" shaped brackets onto the outside of each axle brackets so that the "L" brackets curve inward to the shock mount. **(Figure 16)** The "L" shaped brackets can be mounted on multiple holes of the axle bracket to adjust the vehicle ride height without adjusting the shocks. QA1 recommends using any height that the "L" bracket can be mounted with two bolts per bracket and with (minimum) one vacant hole in between the mounting bolts.

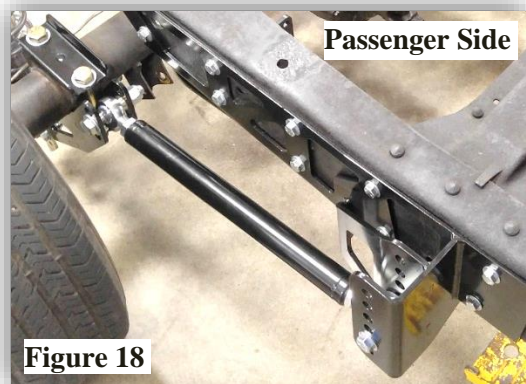

**Figure 16**

**NOTE:**

The shocks that come with this suspension have a recommended length **at ride height** (center/center on the mounting bolts) of 14" to 15". Using the "L" brackets for fine adjustment of the ride height should only be done after final installation and with the shock length at ride height set to 14" to 15".

25. Refer to instructions included with the coil-over shocks for shock and spring assembly.
26. Position the axle under the frame and connect the coil-overs to the notch bracket and axle mount using 1/2" x 2.75" bolts, washers and nylock nuts from the Axle Mount Hardware Kit (p/n 7039-235). Install two 1/8" spacers (part number SLV107 in the lower shock mount between the mounting brackets. **(Figure 17)** Torque coil-over mounting hardware to 50 lb. ft.
27. Support the axle under the frame and connect the trailing arm to the center hole in the axle bracket using 5/8" x 3.5" bolt, washers, and nylock nut from Trailing Arm Hardware Kit (p/n 7039-230). **(Figure 18)** Final torque of 90 lb. ft. Changing the instant center by raising or lowering the arm on this bracket can be adjusted after final ride height is determined.



**Figure 18**

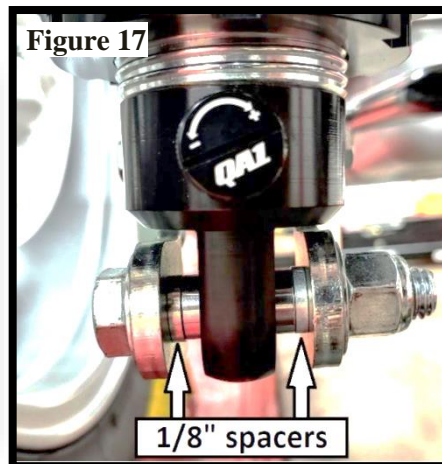

**Figure 17**

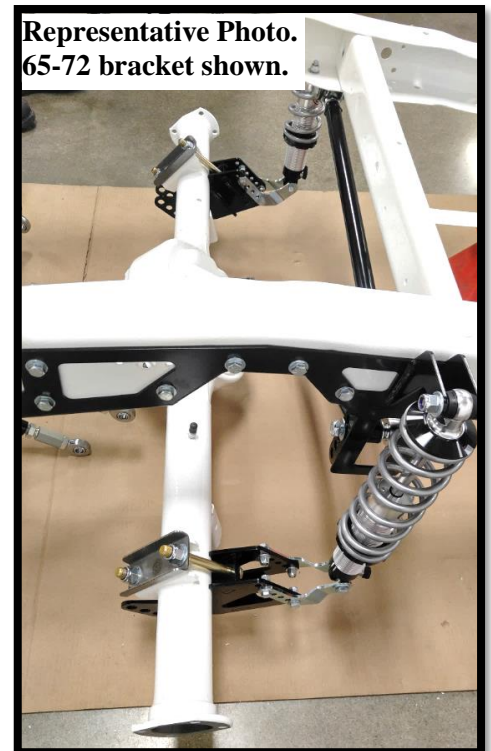

**Representative Photo.  
65-72 bracket shown.**



28. Mount the torque arm bracket to the differential by removing the four drivers side nuts from the front side of the differential. **(Figure 19)** Re-using the original crush washers between the 3rd member and the torque arm bracket, mount the torque arm bracket using blue Loctite on the shouldered nuts from the Torque Arm Hardware Kit (p/n 7039-331). Torque to 37 lb. ft. **(Figure 20 & 21)**

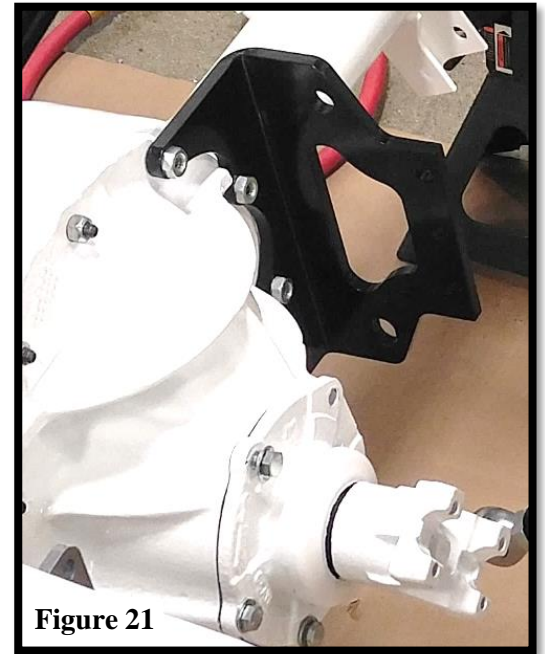
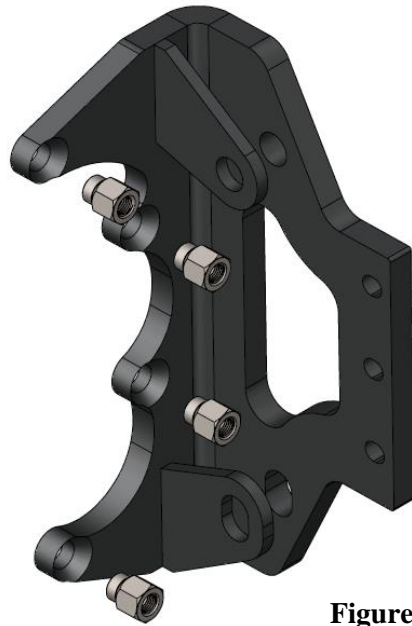
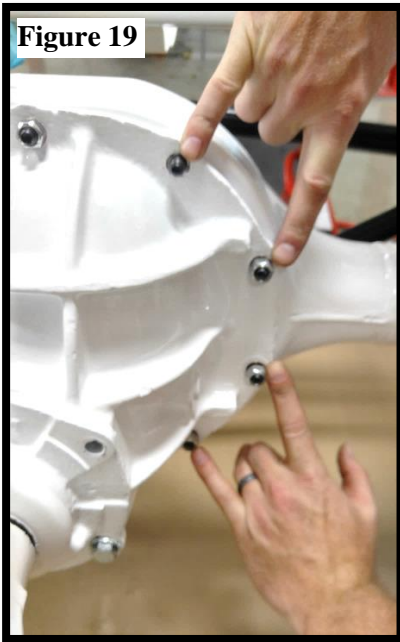

Figure 20

Figure 21

29. Mount the pinion support plate to the torque arm bracket using 3/8" x 1-3/8" bolts and washers. **(Figure 22, Location A)** Bolt the Pinion Mount to the differential using three 3/8" x 1.75" bolts and yellow zinc washers. Torque all to 31 lb. ft. **(Figure 22, Location B)**

The pinion support and torque arm bracket will need to be evenly tightened as to not bind any one area of the assembly.

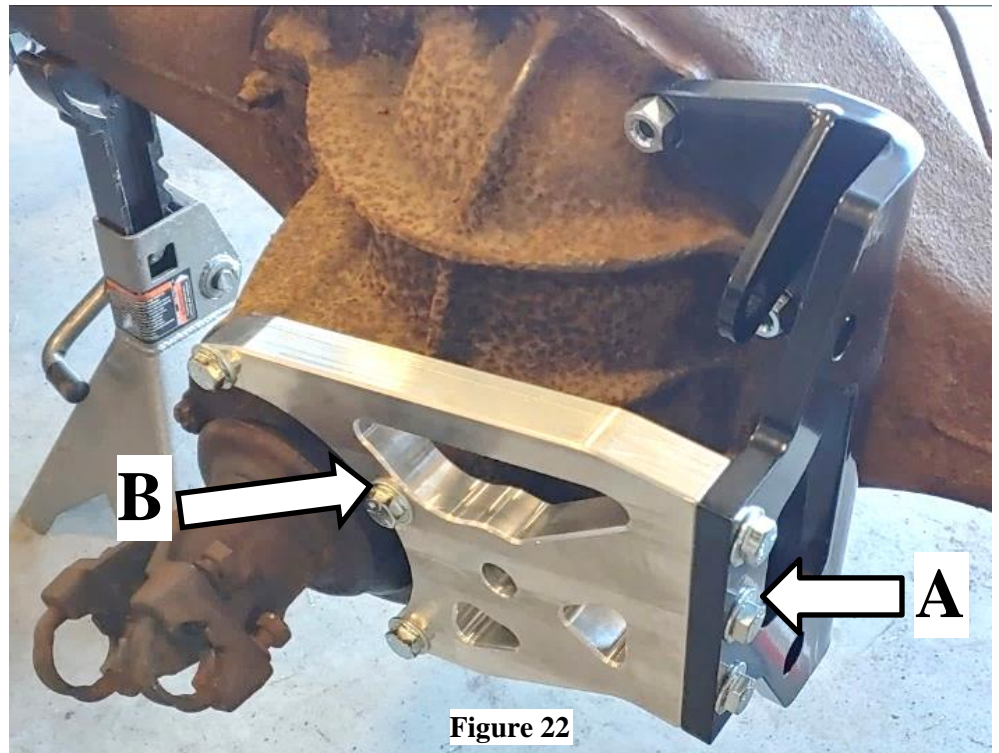
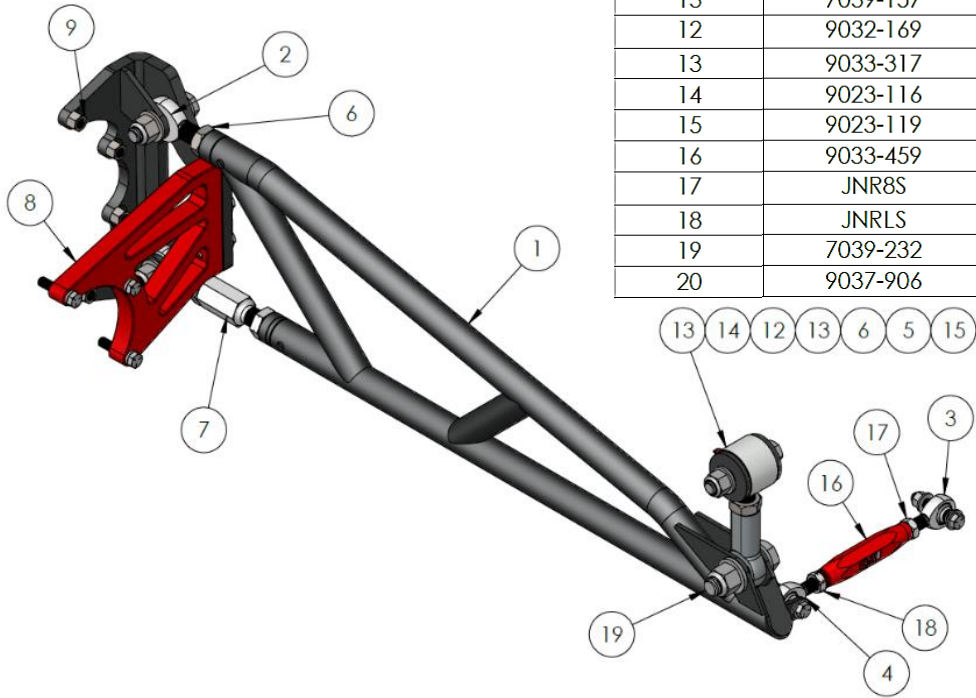

Figure 22

**TORQUE ARM ASSEMBLY-**

30. Install one XMR10-12 rod end (#2) with JNR12S jam nut (#6) into the rear upper connection of torque arm. Screw the rod end fully into torque arm.



BALLOON #	ITEM #	DESCRIPTION	QTY.
1	9037-691	WELDMENT, TORQUE ARM	1
2	XMR10-12	ROD END (X) ENDURA ALLOY HT	2
3	XMR8	ROD END (X) ENDURA ALLOY HT	1
4	XML8	ROD END (X) ENDURA ALLOY HT	1
5	XFR12	ROD END (X) ENDURA ALLOY HT	1
6	JNR12S	JAM NUT, 3/4-16 RH	3
7	AS12-12	LINKAGE ADJUSTER STEEL 3/4-16	1
8	9037-679	BRACKET, FRONT PINION MOUNT	1
9	9037-735	NUT, SHOULDER, 3/8-16 X 5/8 HEX	4
10	SG8-64	HIGH MISALIGNMENT SPACER, .5" OD	4
13	7039-157	Panhard Rod Asm., Short	1
12	9032-169	Bushing, Energy 2042G	2
13	9033-317	Sleeve, .56" ID X .75" OD X 1.88"	1
14	9023-116	CAP, GREASE ZERK	1
15	9023-119	GREASE ZERK, 1/4-28	1
16	9033-459	SLEEVE, .875"HEX ALUMINUM ANODIZED	1
17	JNR8S	Jam Nut, Right Hand Thread	1
18	JNRLS	Jam Nut, Left Hand Thread	1
19	7039-232	HARDWARE KIT, TORQUE ARM	1
20	9037-906	WELDMENT, REAR, 4 BOLT	1

31. Install AS12-12 male to female linkage adjuster (#7) with left hand jam nut into lower torque arm connection. Thread in the remaining XMR10-12 rod end (#2) with jam nut into the linkage adjuster. This linkage adjuster will be your pinion angle adjustment.

32. Install the rear torque arm connection to the torque arm bracket using 5/8" x 2.75" bolts in both connections, two washers per connection, and nylock nuts. Torque to 90 lb. ft.

33. Install a 3/4" jam nut (#6) onto the large rod eye at the front of the torque arm followed by the XFR12 female rod end (#5).



HARDWARE KIT, TORQUE ARM, 65-79 FORD F100		
1st Description	2nd Description	Qty.
BOLT, 9/16-12 X 3.25"	GRADE 5, CLEAR ZINC	1
NUT, NYLOCK, 9/16-12	GRADE 5, CLEAR ZINC	1
WASHER, 9/16, SAE	GRADE 5, CLEAR ZINC	2
BOLT, 3/4-10 X 2.75"	GRADE 5, CLEAR ZINC	1
NUT, NYLOCK, 3/4-10	GRADE 5, CLEAR ZINC	1
WASHER, 3/4, SAE	GRADE 5, CLEAR ZINC	2
BOLT, 5/8-11 X 2.75"	GRADE 5, CLEAR ZINC	2
NUT, NYLOCK, 5/8-11	GRADE 5, CLEAR ZINC	2
WASHER, 5/8, SAE	GRADE 5, CLEAR ZINC	6
BOLT, 3/8-16 X 2.25"	GRADE 5, CLEAR ZINC	2
BOLT, 3/8-16 X 1.375"	GRADE 5, CLEAR ZINC	3
BOLT, 3/8-16 X 1.75"	GRADE 5, CLEAR ZINC	3
NUT, NYLOCK, 3/8-16	GRADE 5, CLEAR ZINC	2
WASHER, 3/8, SAE	GRADE 5, CLEAR ZINC	7
WASHER, 3/8	MS-51412-26, ZINC	3





**WATTS LINK-**

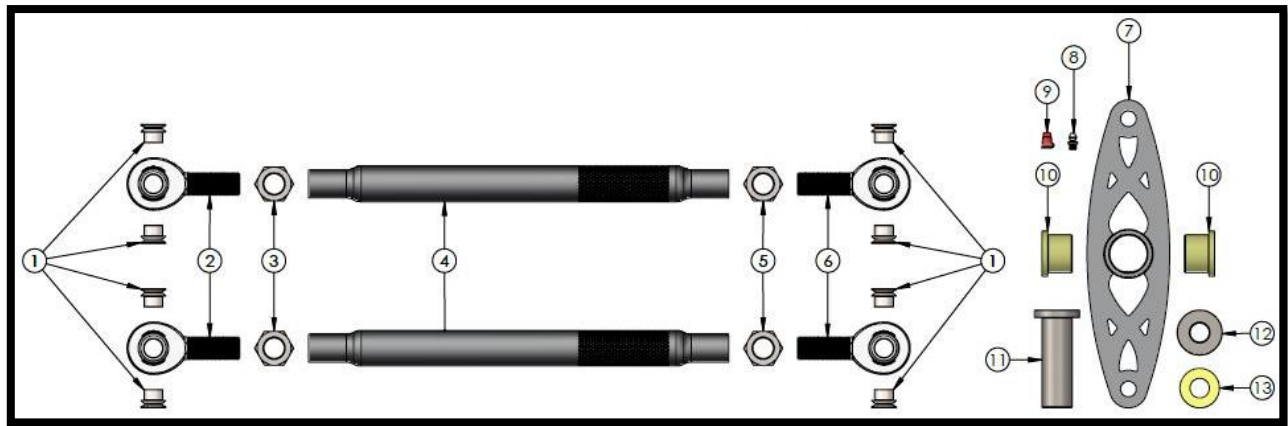

- 34. Insert the bushing halves (#10) into each side of the watts link (#7).
- 35. Insert the flange sleeve (#11) into the bushings of the watts link.
- 36. Mount the watts link to the pinion support plate using the 5/8" x 5-1/2" bolt. The head of the bolt and head of the flange sleeve (#11) will mount towards the front of the truck with the 1.5" O.D. washer (#12) between the watts link and the pinion support. **(Figure 23)**

BALLOON #	ITEM #	DESCRIPTION	QTY.
1	SG10-84	HIGH MISALIGNMENT SPACER, .625" OD	8
2	XMR10-12	ROD END (X) ENDURA ALLOY HT	2
3	JNR12S	JAM NUT, 3/4-16 RH	2
4	1612-133	SWEDGE TUBE, 3/4-16 LH/RH	2
5	JNL12S	JAM NUT, 3/4-16 LH	2
6	XML10-12	ROD END (X) ENDURA ALLOY HT	2
7	9037-1045	WELDMENT, WATTS LINK	1
8	9023-119	GREASE ZERK, 1/4-28	1
9	9023-116	CAP, GREASE ZERK	1
10	9032-393	BUSHING, POLYMER 2-PIECE 1" ID	2
11	9033-517	FLANGE SLEEVE, 1" OD, .635" ID	1
12	9005-315	WASHER, FLAT .64" ID 1.5" OD	1
13	9005-130	WASHER, FLAT 5/8" SAE HARDENED	1

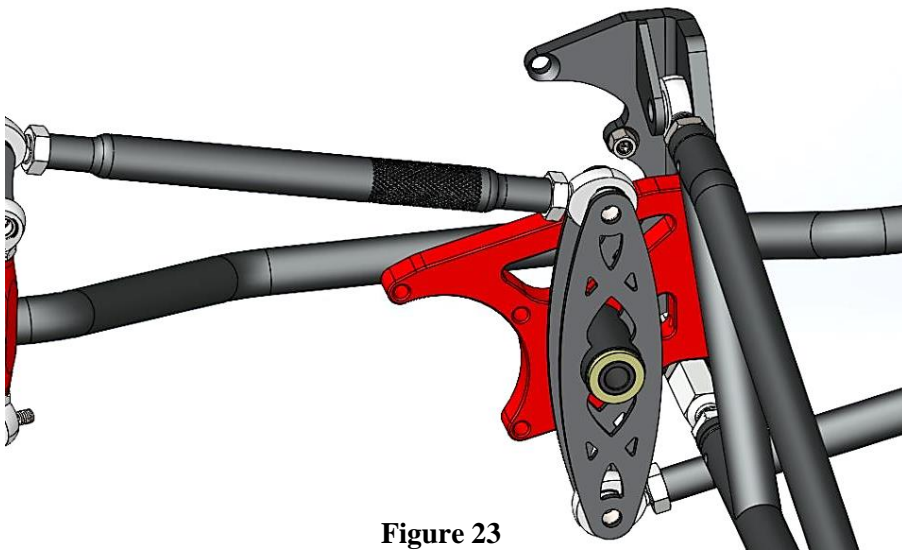

**Figure 23**

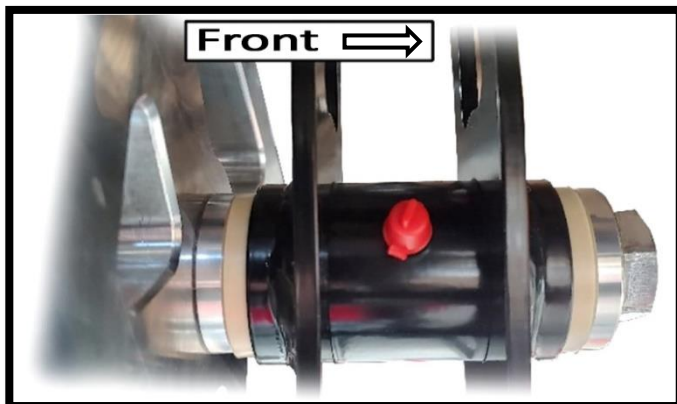

- 37. On the back side of the pinion support plate, install the 5/8" hardened washer (#13) and the 5/8" nyloc nut to secure. Torque to 80 lb. ft.



38. Assemble the swedge tubes (#4) with the jam nuts (#3, #5) and rod ends (#2, #6) noting that one end of the swedge tube is threaded left-hand and one end is threaded right-hand, as are the jam nuts and rod ends. Assemble to the shortest length possible.



39. Install one SG10-84 spacer (#1) into each end of both rod ends. (Figure 24)

**NOTE:**

These swedge tubes will be easier to install once the torque arm and front crossmember are installed later in these instructions.

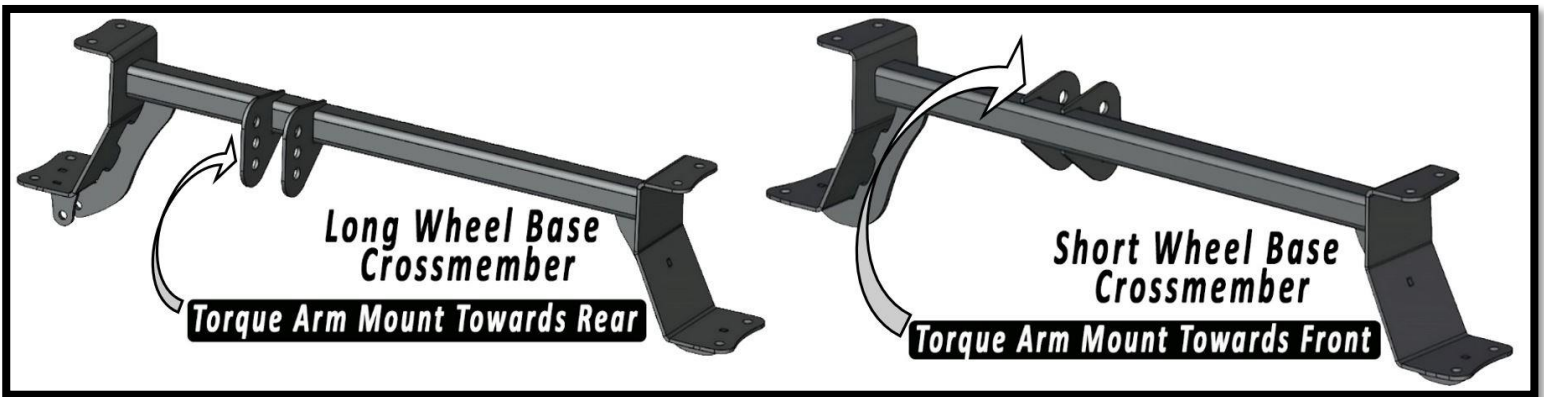

Figure 24

**FRONT CROSSMEMBER INSTALL-**

**NOTE:**

The location of the torque arm mount is different on the Short Wheel base and Long Wheel Base crossmembers. Verify that you have the correct crossmember for your truck length before moving forward.



40. Slide the front crossmember between the frame rails with the torque arm mount oriented in the correct position (dependent on the trucks wheel base shown above).

41. Bolt the support brackets to the crossmember using 7/16" x 1.25" hardware with two washers per connection and nyloc nut. The upper brackets are not right/left specific. Torque to 49 lb. ft. (Figure 25)

**NOTE:**

The crossmember does not need to be mounted onto the frame at this time. Crossmember mounting is covered after the torque arm is installed in the next steps.



Figure 25



42. Install the torque arm to the torque arm axle bracket using 5/8" x 2.75" bolts, two washers per connection, and nylock nuts. Torque to 90 lb. ft.
43. Mount the large rod eye on the front of the torque arm to the center hole of the (loose) front crossmember using 3/4" x 2.75" bolt, two 3/4" washers, and 3/4" nyloc nut. Torque to 130 lb. ft. **(Figure 26)**

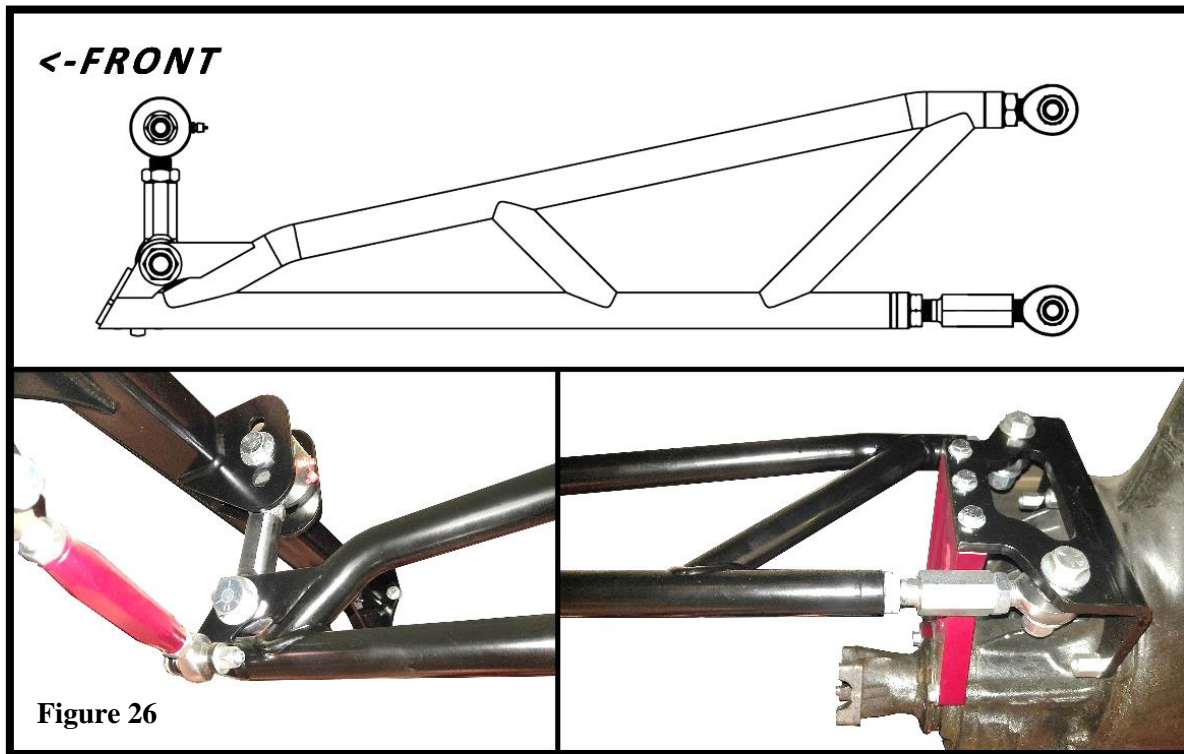

**Figure 26**

**TORQUE ARM CROSSMEMBER-**

44. The front crossmember is located by mounting it the distance listed below. The top side measurement is from the factory cross-member rivet. If the bed has not been removed, reference the hole to hole length of the cross-member and frame notch bracket. See the measurements below to verify the crossmember mounting location. **(Figure 27)**
45. With the location of the torque arm crossmember determined, drill the three frame holes and secure using 7/16" x 1.25" bolts, two washers per connection, and nyloc nuts.
46. Install a 1/2" right-hand threaded jam nut onto one XMR8 rod end. Thread the rod end into the right-hand side of the red aluminum adjuster sleeve.
47. Install a 1/2" left-hand threaded jam nut onto one XML8 rod end. Thread this rod end into the left-hand threaded end of the red aluminum adjuster sleeve.
48. Install one SG8-64 high misalignment spacer in each side of both rod ends. (4 total) **(Figure 28)**

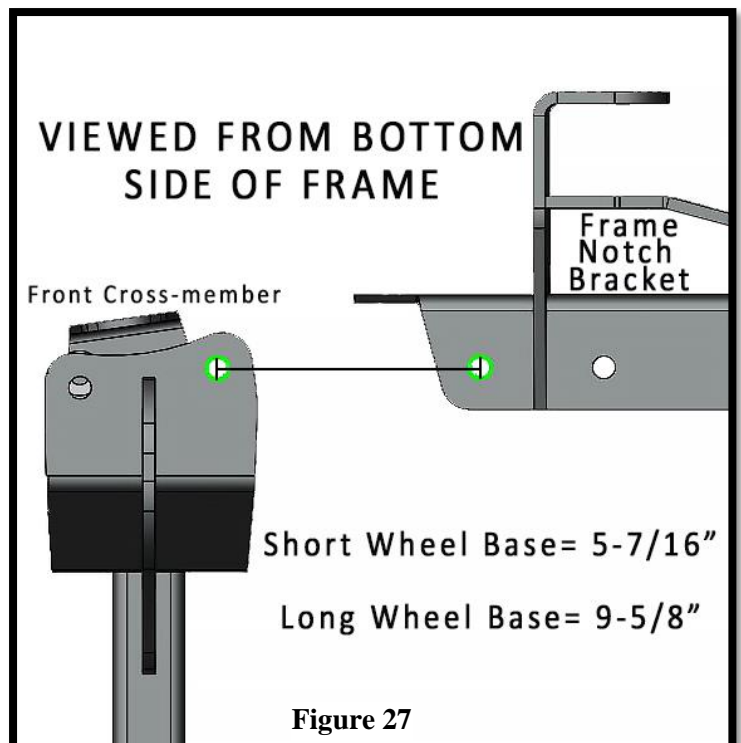

**Figure 27**

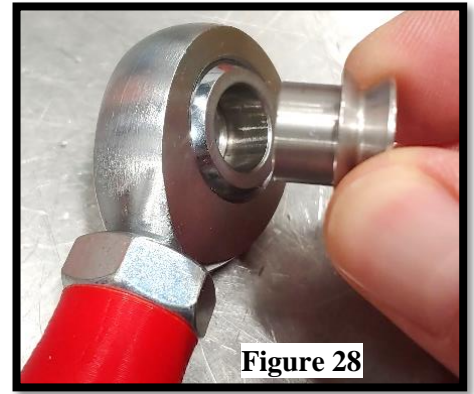

Figure 28

**NOTE:**

On Long bed versions of this suspension the bracket that the torque arm stabilizer rod connects to is part of the frame notch bracket. On Short Wheel Base models the frame mount will be a separate bracket and not part of the frame notch bracket. (Figure 29)

**LONG WHEEL BASE**



Stabilizer rod mounts directly to the torque arm crossmember Figure 29

**SHORT WHEEL BASE**



49. Install the assembled adjuster sleeve into the front side bracket of the torque arm. Secure to the torque arm using 3/8" x 2.25" bolt, two washers per connection, and nyloc nut. Torque to 31 lb. ft.

50. Attach the frame side of the stabilizer rod to the torque arm crossmember (long bed). Short bed applications will need to mount the stabilizer rod to the detached bracket (seen above). Mark and drill a location that mounts the rod perpendicular to the frame rail. Secure this connection using 3/8" x 2.25" bolt with two washers and nyloc nut. Torque to 31 lb. ft.

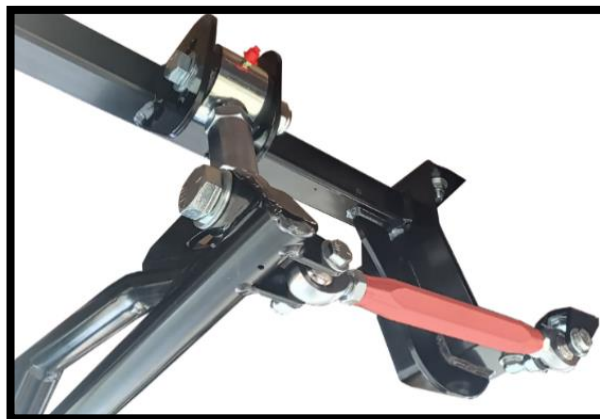



### SWAGED TUBES TO WATTS LINK-

51. Connect the driver side watts link to the notch bracket using the swaged tubes assembled in step 38. The passenger side swaged tube will connect the top of the watts link to the passenger side inner frame bracket shown in **Figure 10**.



### E-BRAKE CABLE MOUNT-

52. Mount the e-brake support plate to the factory cross-member by drilling new 7/16" holes and using 7/16" x 1.25" bolts, washers, and nylock nut. Torque to 49 lb. ft. (**Figure 30**)
53. Re-route the e-brake cables above the factory crossmember and secure the factory e-brake lever assembly to the e-brake pivot using 5/16" shouldered bolt, washers, and nylock nut. (**Figure 30**)



### TRUCKS WITH TWO-PIECE DRIVESHAFTS-

If your truck has a two-piece driveshaft this suspension kit comes with an updated carrier bearing support. Install using the included 7/16" x 1.25" hardware with two washers and one nyloc nut per connection **TRUCKS WITH ONE-PIECE DRIVESHAFTS WILL NOT NEED THIS CARRIER BEARING SUPPORT.**



## **FINALIZING THE INSTALLATION:**

1. Adjust the spring seat collars on the coil-overs up the shock body so that there is 2" of threads under the collars before slowly lowering the truck down to check the ride height. Use caution as the truck may sit lower than anticipated.
2. Raise the truck and adjust the collars up or down to achieve the desired ride height. When the desired ride height is achieved, tighten the locking collar against the spring seat collar to lock in the adjustment.
3. Re-install brake lines and bleed the brake system.
4. Make any changes to the trailing arm and panhard bar mounting points to ensure both are parallel to the ground and the wheel base is true at your desired ride height.
5. Adjust the torque arm front support so the torque arm is parallel with the frame rails.
6. Make final pinion angle adjustment at ride height. A typical starting point would be the pinion facing down 1 degree.
7. Double check all hardware connections and snug all jam nuts.

**A professional four-wheel alignment is required before driving the vehicle.**

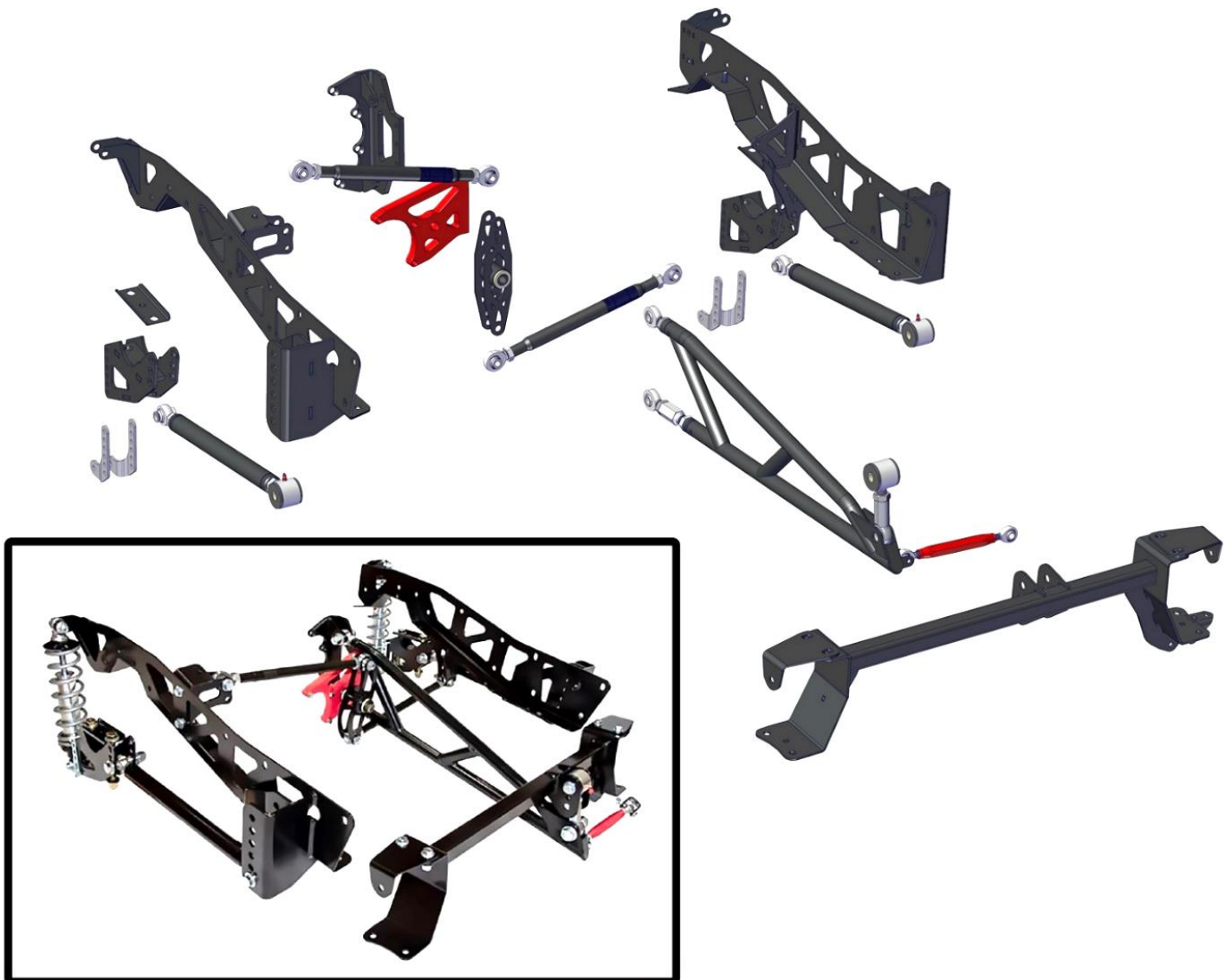





Technical Support Line: (952) 985-5675 Email: sales@QA1.net

READ ALL INSTRUCTIONS CAREFULLY AND THOROUGHLY PRIOR TO STARTING INSTALLATION. PRODUCTS THAT HAVE BEEN INSTALLED ARE NOT ELIGIBLE FOR RETURN. USE THE PROPER JACKING LOCATIONS. DEATH OR SERIOUS INJURY CAN RESULT IF INSTRUCTIONS ARE NOT CORRECTLY FOLLOWED. A GOOD CHASSIS MANUAL, AVAILABLE AT YOUR LOCAL PARTS STORE, MAY ALSO AID IN YOUR INSTALLATION.

• DISCLAIMER / WARRANTY •

QA1 WARRANTS THAT THE PRODUCTS WILL BE FREE FROM DEFECTS IN MATERIAL AND WORKMANSHIP FOR ONE YEAR FROM DATE OF SALE TO THE ORIGINAL PURCHASER. QA1 MAKES NO OTHER WARRANTY OF ANY KIND, EXPRESS OR IMPLIED. QA1 SHALL HAVE NO OBLIGATION UNDER THE FOREGOING WARRANTY WHERE THE DEFECT IS THE RESULT OF IMPROPER OR ABNORMAL USE, YOUR NEGLIGENCE, VEHICLE ACCIDENT, IMPROPER OR INCORRECT INSTALLATION OR MAINTENANCE, NOR WHEN THE PRODUCT HAS BEEN REPAIRED OR ALTERED IN ANY WAY. QA1'S LIABILITY IN THE CASE OF DEFECTIVE PRODUCTS SUBJECT TO THE FOREGOING WARRANTY SHALL BE LIMITED TO THE REPAIR OR REPLACEMENT, AT QA1'S OPTION, OF THE DEFECTIVE PRODUCTS.

THE USER UNDERSTANDS AND RECOGNIZES THAT RACING PARTS, SPECIALIZED STREET ROD EQUIPMENT, AND ALL PARTS AND SERVICES SOLD BY QA1 ARE EXPOSED TO MANY AND VARIED CONDITIONS DUE TO THE MANNER IN WHICH THEY ARE INSTALLED AND USED. QA1 SHALL BEAR NO LIABILITY FOR ANY LOSS, DAMAGE OR INJURY, EITHER TO A PERSON OR TO PROPERTY, RESULTING FROM THE INSTALLATION, DIRECT OR INDIRECT USE OF ANY QA1 PRODUCTS OR INABILITY BY THE BUYER TO DETERMINE PROPER USE OR APPLICATION OF QA1 PRODUCTS. WITH THE EXCEPTION OF THE LIMITED LIABILITY WARRANTY SET FORTH ABOVE, QA1 SHALL NOT BE LIABLE FOR ANY CLAIMS, DEMANDS, INJURIES, DAMAGES, ACTIONS, OR CAUSES OF ACTION WHATSOEVER TO BUYER ARISING OUT OF OR CONNECTED WITH THE USE OF ANY QA1 PRODUCTS. MOTORSPORTS ARE DANGEROUS; AS SUCH, NO WARRANTY OR REPRESENTATION IS MADE AS TO THE PRODUCT'S ABILITY TO PROTECT THE USER FROM INJURY OR DEATH. THE USER ASSUMES THAT RISK!

# DEDICATED TECH SUPPORT

QA1 is dedicated to providing quality support and instructions. We employ passionate racers and car enthusiasts that know our products and the industry to better serve you.

*CHECK US OUT ON YOUTUBE!*



- Frequently Asked Questions
- Quick Tips
- Install Information
- Tuning and Repair Guides
- Other Technical Information



- [linkedin.com/company/qa1](https://www.linkedin.com/company/qa1)
- [instagram.com/qa1motorsports](https://www.instagram.com/qa1motorsports)
- [facebook.com/qa1motorsports](https://www.facebook.com/qa1motorsports)

[www.qa1.net/tech](http://www.qa1.net/tech)

[youtube.com/qa1tech](https://www.youtube.com/qa1tech)