



These instructions can be found in color and expandable at QA1.net

Technical Support Line: (952) 985-5675 Email: sales@QA1.net

INSTALLATION INSTRUCTIONS

QA1 P/N 52622-xxxx '63-'72 C10 Front Suspension
52623-xxxx '73-'87 C10 Front Suspension
52624, 52625 '63-'87 C10 Crossmember

TOOLS AND SUPPLIES REQUIRED

- Floor Jack
- Jack Stands
- SAE Wrench Set
- Ratchet & SAE Socket Set
- 1891-106 Ball Joint Tool Kit
- Torque Wrench
- Grinder or Air Chisel
- Drill & Drill Bit Set

ADDITIONAL PARTS REQUIRED

- Steering Shaft & U-Joints
- Power Steering Lines & Fittings
- '73-'87 C10 Spindles
- Optional – Brake Upgrades

PRE INSTALLATION NOTES:

For installation of this QA1 crossmember to trucks already using QA1 front suspension please see the retrofit section of these instructions on page 14.

This suspension requires the use of factory or aftermarket 73-87 C-10 spindles. Standard height or drop spindles can be used depending on the desired drop.

Double check that all hardware is on hand before beginning this installation. (Page 18)

DISSASSEMBLY INSTRUCTIONS:

1. While not necessary, QA1 recommends removing the hood, front bumper and front clip for this installation.
2. Remove the engine and transmission. If using a lift, ensure the trucks weight will be balanced without the weight of the engine.
3. Raise the truck and support the frame using jack stands on a stable surface.

NOTE:

The factory crossmember and front suspension can be removed from the truck as a single unit. If a transmission jack or other supporting device isn't available the control arms, springs, and steering linkage can be removed as individual items to reduce the amount of weight being removed at one time.

4. Remove the shocks from the upper shock mount.
5. Remove the steering shaft, tie rod ends, and disconnect the brake lines. For '73-'87 models, the brake hose must be removed from the upper control arms before removing the crossmember.
6. Remove the idler arm and steering box.
7. Remove the four bolts holding the upper control arm mount to the frame rail. (Figure 1) (photo shown with upper control arm already removed)
8. Support the factory crossmember in preparation for removal. If using a lift, consider the trucks weight balance without the weight of the front suspension/crossmember when choosing lift points.

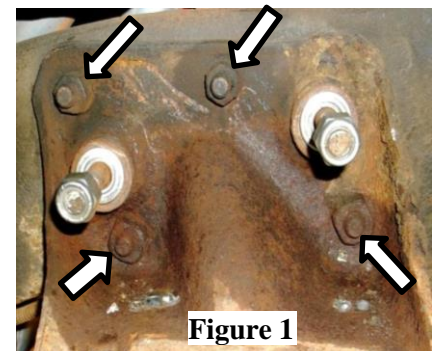
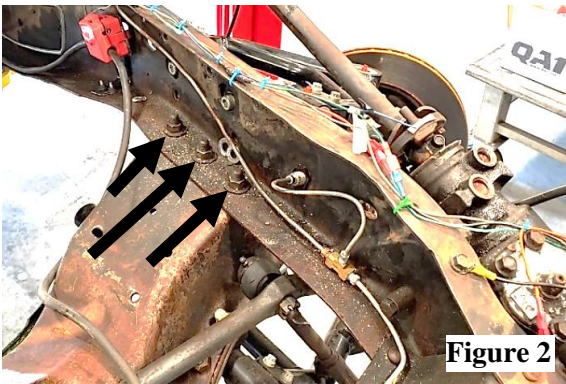

Figure 1

- Remove the six crossmember mounting bolts (3 per side). **(Figure 2)**



- Clean the frame rails of any dirt or rust in preparation for the crossmember install. Now is a great time to apply paint or corrosion inhibitor to the frame rails.

CROSSMEMBER INSTALLATION:

- Raise the QA1 crossmember into place locating it with the center hole that the factory crossmember was attached to. Install the crossmember with the engine mounting bushing cans towards the rear of the truck. **(Figure 3)** Secure the crossmember to the frame using 1/2" x 1-1/2" hardware through this center hole. Use two washers and one nyloc nut per connection.

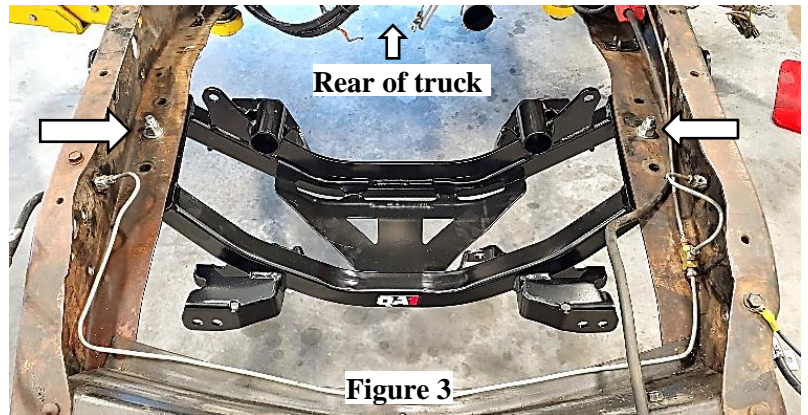

- Center punch and drill the two lower side-frame holes and the two upper holes of the QA1 crossmember. The lower holes will be drilled using a 3/8" drill bit while the upper holes should be drilled to 1/2". Install 3/8" x 1-1/4" hardware into **the lower holes only** with two washers and one nyloc nut per connection. (The upper holes will be used later to install the upper control arms.) The use of C-clamps will aid in lining up/holding the crossmember to the frame. **(Figure 4)**
- Center punch and drill a pilot hole for the four crossmember bolt holes (four per side) on the underside of the frame before final drilling them to 3/8". Install 3/8" x 1-1/4" hardware using two washers and one nyloc nut per connection. Torque to 31 lb. ft. **(Figure 5)**

Due to frame height differences, the crossmember will extend above the frame rails on 1963-1972 trucks.

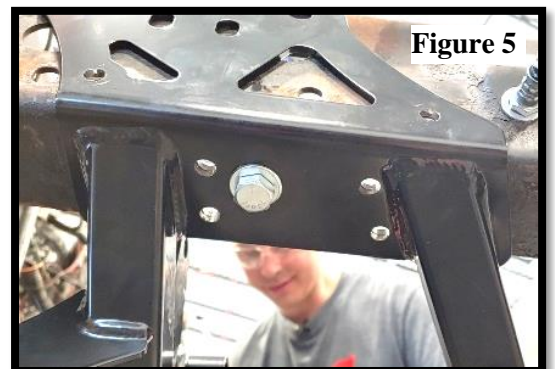
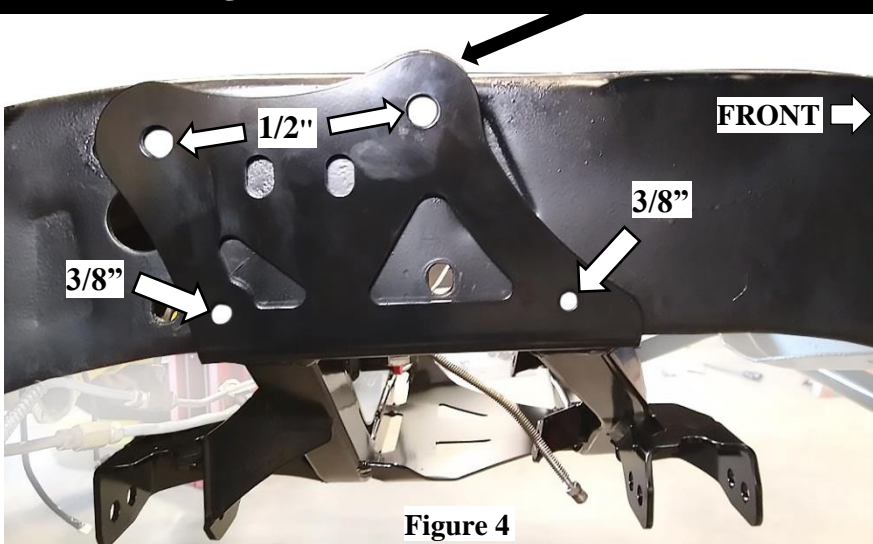

4. Locate the aluminum upper shock mount onto the crossmember frame. **(Figure 6)** These upper shock mounts are identical and not right/left specific. The two bolt holes on the wheel side will line up with the two slotted holes of the crossmember. The slotted holes of the crossmember account for variances in frame rail height.
5. Clamp the upper shock mount to the frame rail. Use a punch and drill a pilot hole before drilling the top two holes to 1/2" and the two frame side holes to 1/2". One of the upper mounting holes is offset of a factory hole. This hole was not designed to line up with the factory hole. **(Figure 7)**

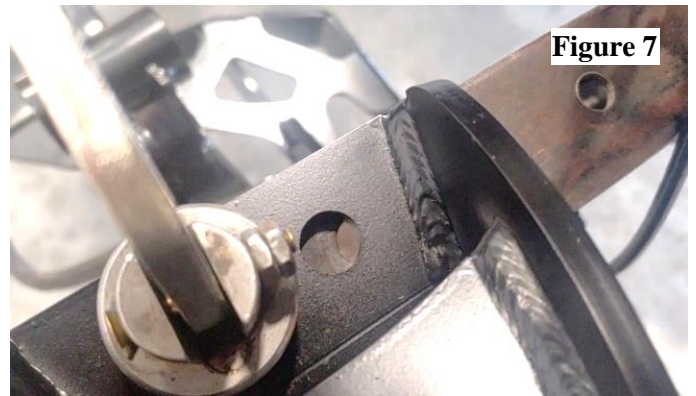
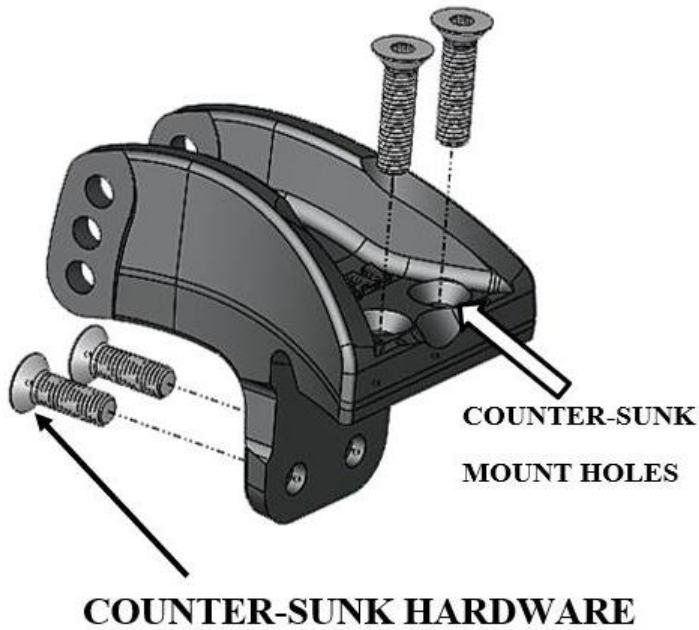

6. Identify the right and left inner frame bracket. **(Figure 8)** Bolt the inner frame bracket and upper shock bracket to the frame using 1/2" x 1.5" hardware with two washers and one nyloc nut per connection. These connections should be final torqued to 75 lb. ft. once the suspension is installed and loaded.

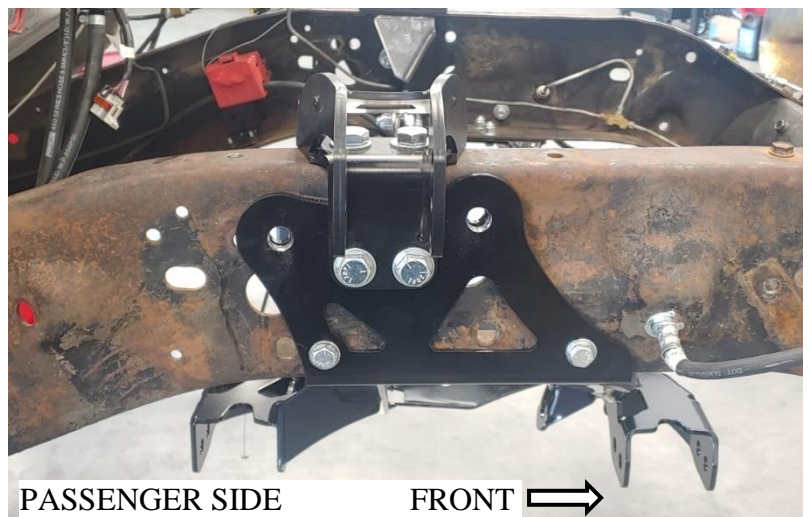
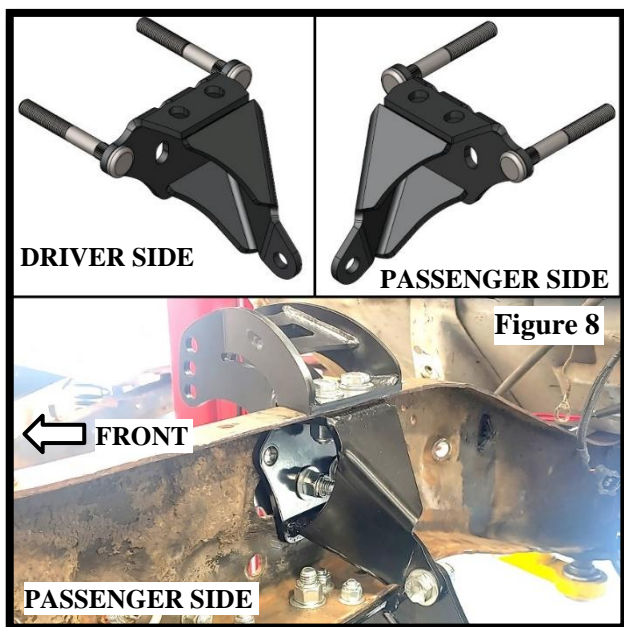

LOWER CONTROL ARMS:

7. Identify the driver and passenger side lower control arms by the sway bar mounting tabs facing forward with the ball joint stud facing up. **(Figure 12)**
8. Loosely install the bushing housings to the lower control arm with the grease fittings facing down. the included 12-point 3/8" hardware with two washers and nyloc nut per connection. The bushing mount hardware should only be torqued to 44 lb. ft. after the control arm is installed to the crossmember. **(Figure 9)**
9. Insert one black aluminum sleeve into each bushing mount. **(Figure 10)**
10. Insert one aluminum spacer on each end of the bushing housing with a dab of grease on each spacer. **(Figure 11)** The grease will help hold these spacers in place while installing the arm to the crossmember.

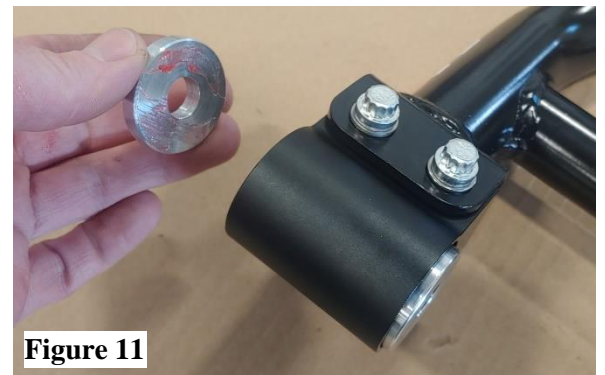
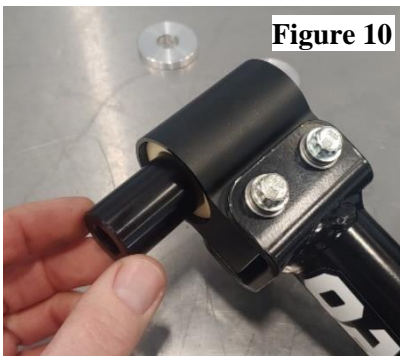

11. Install one straight bracket and one bent bracket into the lower control arm with the bent bracket towards the inboard side of the arm using a 1-1/4" long sleeve between the brackets and within the mounting tabs. Use 1/2" x 3" hardware on the inboard connection and 1/2" x 1-3/4" hardware on the ball joint side of the arm with two washers and one nyloc nut per connection. These two brackets will create the lower shock mounting point and should be torqued to 50 lb. ft. after the shock is installed into them in step 25.

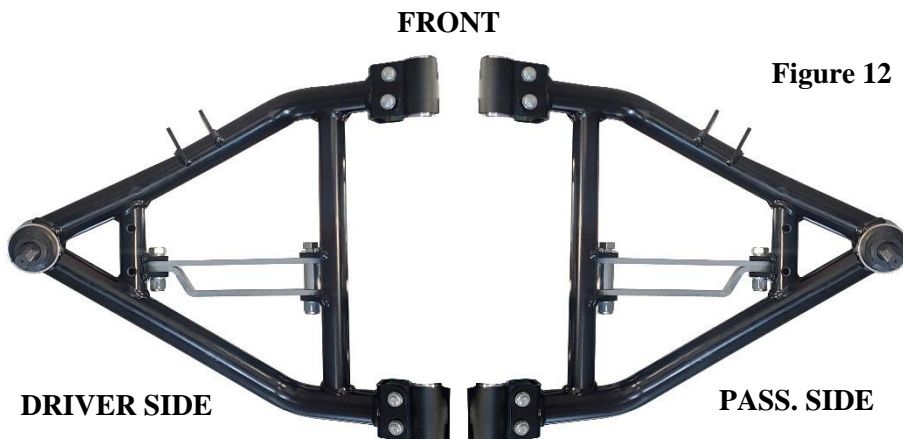

12. Install the control arms to the outer-most hole of the crossmember using 1/2" x 4" bolts with two washers and one nyloc nut per connection. Torque to 50 lb. ft. The additional inboard hole in the crossmember is for specialty applications needing additional positive camber.

13. Once the arm is installed, torque the bushing housing to arm 12-point 3/8" hardware to 44 lb. ft.

UPPER CONTROL ARMS:

14. Identify the Driver (LH) and Passenger (RH) side upper control arms. **(Figure 13)**

15. Install one stainless 1-3/8" O.D. x 5/8" I.D. spacer onto the upper control arm mounting stud with the beveled side facing the beveled side of the crossmember plate. **(Figure 14)**

16. Install and secure the upper control arms using 1/2" washers and two fine-thread nyloc nuts per upper arm. Torque the upper control arm to 50 lb. ft. The alignment shop will later add/remove shims from this mount to set the alignment.

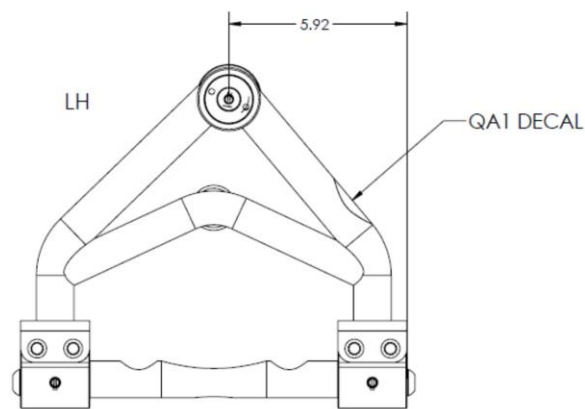

Figure 13

FRONT

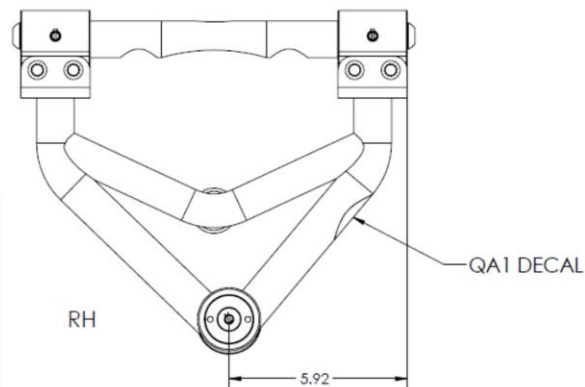

Figure 14

SHOCK ASSEMBLY:

17. Holding the upper shock eyelet, loosen the jam nut at the base of the eyelet and unthread the eyelet from the shock rod.

18. Install the large rubber bump stop onto the shock rod which is included in the 7878-104 bump stop tuning kit.. **(Figure 15)**



Figure 15

NOTE:

Also included in the bump stop tuning kit is one 1/2" shim and four .125" shims. These shims can be used to limit compression travel on competition vehicles but are otherwise **NOT NEEDED**.



- 19. Thread the aluminum locking collar (shoulder up) onto the shock, followed by the spring seat collar (shoulder up) down to the bottom shock thread - NO FURTHER. Now is a good time to lubricate the threads of the shock with **Permatex® Anti-Seize lubricant**.
- 20. QA1 highly recommends using the optional Thrust Bearing Kit (QA1 P/N 7888-109) for ease of adjustment. If the thrust bearing kit is used, coat both sides of the washers with **Permatex® Anti-Seize lubricant**. Install the stainless steel spring seat washer, followed by the bearing and finally, the second washer. When complete, the thrust bearing kit will resemble a "needle bearing sandwich". When using the thrust bearing kit the stainless steel washer that came with your shock will not be needed.

- 21. If the thrust bearing kit is not used, coat one side of the stainless steel spring seat washer that came with your shock with **Permatex® Anti-Seize lubricant**. Place the lubricated side of the washer down on the spring seat.
- 22. Pull the piston rod out to its fully extended position. This will be easier with the shock adjustment knob(s) turned counter-clockwise to the softest setting.
- 23. Thread the jam nut onto the piston rod down to the lowest threads.
- 24. Slide the spring over the shock down to the spring seat adjuster and install the upper spring cap. **(Figure 16)**
- 25. Apply a small amount of anti-seize to the inner cup of the spring cap before threading the extended shock eyelet onto the piston rod. Sneak a 7/8" open-ended wrench through the spring to snug the jam nut against the upper spring cap. **(Figure 17)**

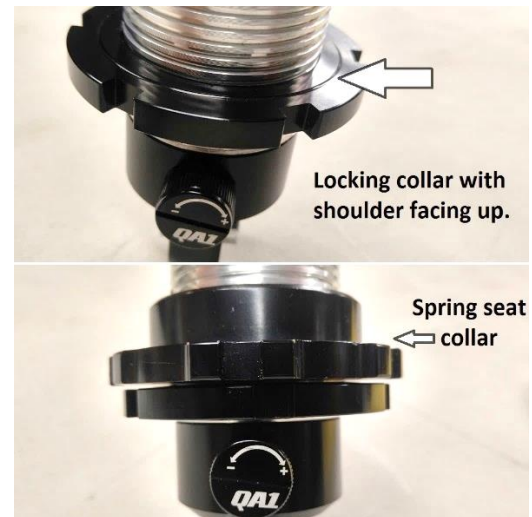

Permatex® Anti-Seize lubricant

Rev. 03212024



Figure 16



Figure 17

26. Install the included spherical bearing kit into the lower shock mount using the following steps:

TOP TIP:

Press a flat head screwdriver or similar around the c-clips to ensure they are fully seated into the grooves of the shock eyelet.

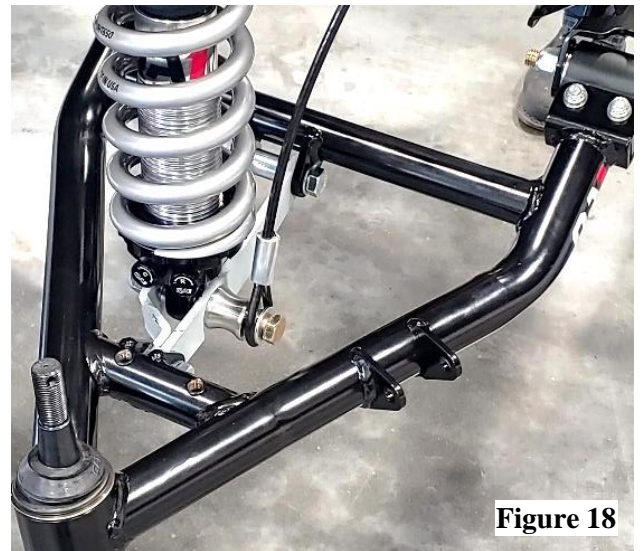
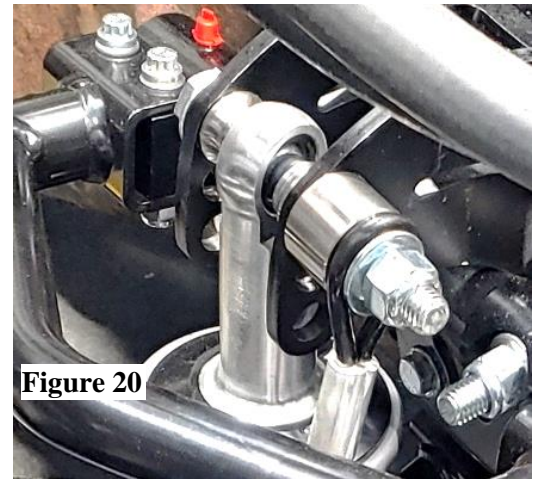
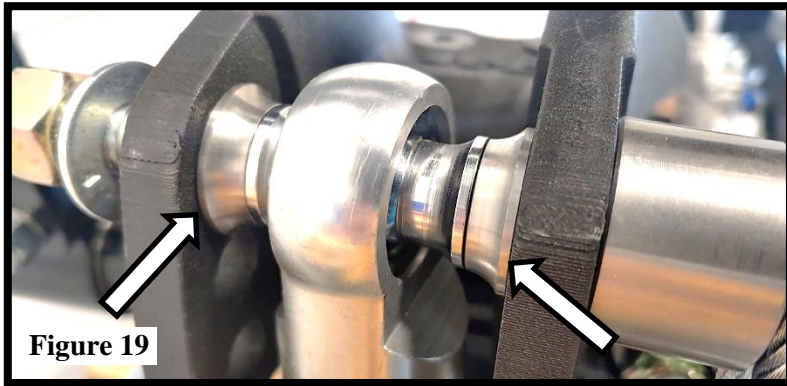

Figure 18



SHOCK INSTALLATION:

- 27. Install the shock into the lower control arm. This suspension comes with limiting cables and cable spacers/mounts. Use the wider/beveled spacer/cable mount on the lower connection with the limiting cable mounted towards the front side of the truck. Secure using 1/2" x 4" hardware with two washers and one nyloc nut. **(Figure 18)** Torque to 50 lb. ft.
- 28. In order to install the limiting cable and upper shock mount the lower control arm will need to be raised to slightly compress the suspension. Once the suspension is compressed, install the narrow/straight cut spacer/cable mount and the shock to the center hole of the frame mount with one high misalignment spacer on each side of the shock eyelet. **(Figure 19)** 1/2" x 4-1/2" hardware with two washers and one nyloc nut. **(Figure 20)** The additional holes in the upper shock mount add the ability to slightly lower or raise the trucks ride height without changing the shock length.

ENGINE MOUNT INSTALLATION:

ENGINE PLACEMENT NOTES:

The recommended engine mounting configurations are designed to fit the engine in the stock location. Engine mounting plates and/or pedestals can be flipped to change the placement of the engine at the builders discretion. Additionally, QA1 offers a weld-it DIY engine mount kit for customizing engine placement- Part number 7740-378. Changing the position of the engine will affect the driveline length and angle.

'67-'87 trucks running Big Block engines- If the head of the carriage bolt in the mounting plate contacts the frost plug on the block you will need to install spacers between the plates/engine. **(Figure 21)**

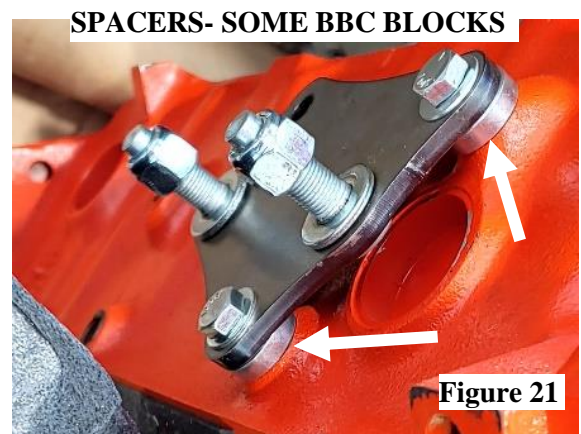

29. Identify the right/left engine mounts and mounting plate orientation based on the diagram to the right: (all mounts shown are the right/passenger side. Driver side mounts will mirror the right/passenger side.)

30. Install two bushing halves into each bushing can on the crossmember and push the included sleeve into the bushing mount after coating with the supplied bushing grease. **(Figure 22)** Using a large clamp or channel locks will assist with installing the sleeve.

31. Install the engine mounting plates with the supplied carriage bolt heads behind the plate to the engine using customer supplied hardware. Follow the driver side layout with the passenger side installed to mirror the driver side.

32. Install the engine mounting pedestals loosely to the engine and bring the engine into position onto the crossmember.

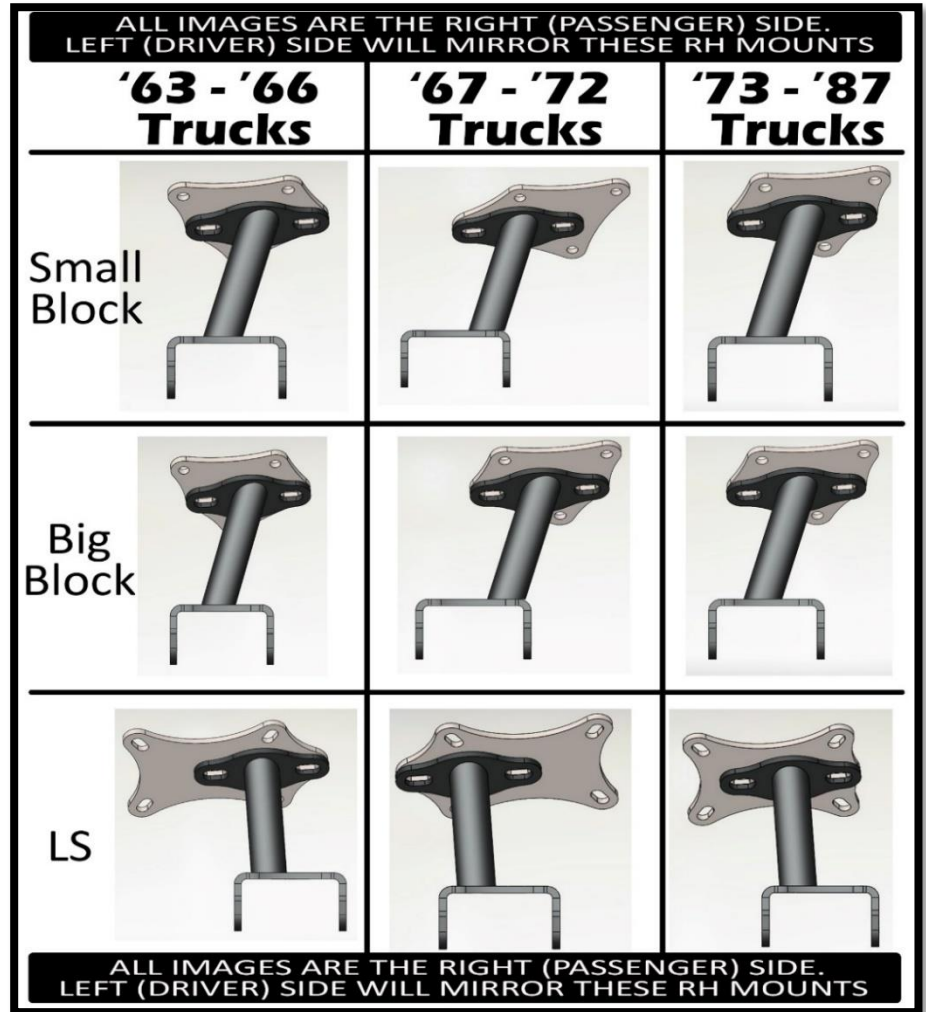

33. Install the 1/2" x 5" through bolts through the engine mounting pedestals and the bushing cans with two washers per connection and one nyloc nut. Torque to 50 lb. ft.

SUGGESTED PARTS LIST:

Oil Pans	Headers
<ul style="list-style-type: none">- SBC<ul style="list-style-type: none">• Stock, rear sump- BBC<ul style="list-style-type: none">• Stock, rear sump- LS<ul style="list-style-type: none">• 4th Gen F-body Dorman 264-331<ul style="list-style-type: none">- Will not fit stock '67-'72 position• Holley 302-1 or 302-2	<ul style="list-style-type: none">- SBC<ul style="list-style-type: none">• Hedman 62010• Hedman 69010• Hooker 2452HKR- BBC (Modification may be required)<ul style="list-style-type: none">• Hedman 69170• Hedman 68610• Hooker 7517HKR- LS<ul style="list-style-type: none">• Schoenfeld 1302LS1 (Modification may be required)• Hedman 69710• Dougs Headers D3348

STEERING RACK INSTALLATION:

34. Find and set the travel of the steering rack to the center. This rack is 2-3/4 turns lock to lock.
35. Slide the steering rack through the crossmember from the driver (left) side. The input shaft of the rack can be rolled slightly towards the rear of the truck to maneuver the rack into place.
36. Secure the rack to the crossmember using 5/8" x 3-3/4" hardware with one 1-3/4" diameter washer under the bolt head and one 1-1/4" washer under the nut. Both bolt heads should be installed towards the rear of the truck with the nuts towards the front of the truck. Torque the rack mount hardware to 90 lb. ft.

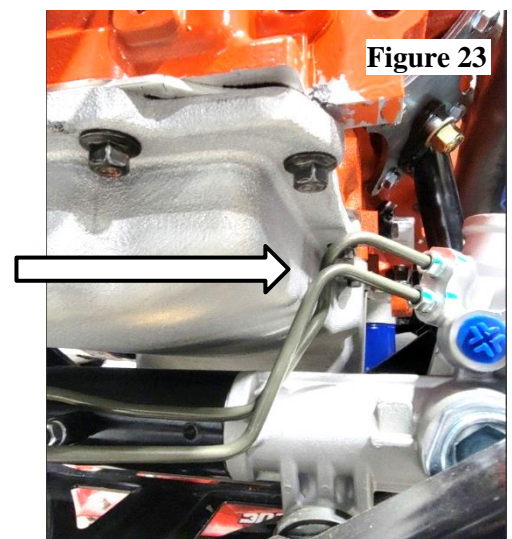

37. **On LS swapped trucks**, check the clearance of the hard line coming off the steering rack on the driver side to ensure clearance with the oil pan. Slight pressure on the hardline can be used to ensure it is not making contact. (Figure 23)

SPINDLE / TIE ROD INSTALLATION:

38. Install the spindle onto the lower ball joints using one zinc coated 5/8" washer (3/16" thick) under the castle nut. Torque to 65 lb. ft. Continue tightening to line up the cotter pin hole with the castle nut. **Never loosen the nut to line up the cotter pin hole.**
39. Install the upper ball joint into the spindle with one 1/2" washer and castle nut. Torque to 50 lb. ft. Continue tightening to line up the cotter pin hole with the castle nut. **Never loosen the nut to line up the cotter pin hole.**
40. With the jam nut provided with the steering rack still in place, thread the right-hand threaded end of the tie rod sleeve onto the steering rack with one thread. **(Figure 24)**
41. Thread one left-hand jam nut onto the XML12 rod end down to the head of the rod end.
42. Thread the left-hand threaded rod end into the tie rod sleeve with one thread started. Holding the rod end in place, turn the tie rod sleeve so that both inner and outer tie rods thread evenly into the sleeve until they bottom out against each other. **(Figure 25)**
43. Insert one misalignment spacer into each side of the rod end bore. **(Figure 26)**



Figure 24

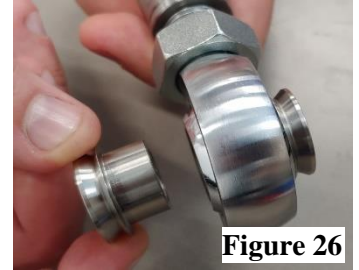

Figure 26



Figure 25

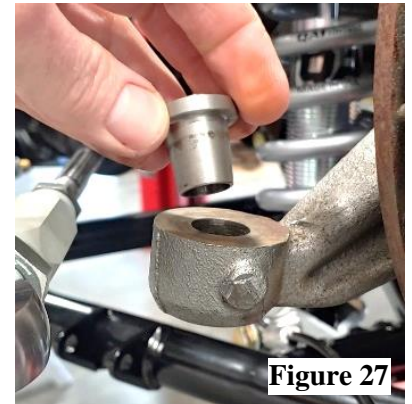

Figure 27

44. Install the included tapered sleeve into the top of the spindles steering arm. **(Figure 27)**

14. Install the tie rod to the lower side of the spindle steering arm with the head of the bolt on the bottom. The included beveled tie rod spacer is used between the spindle/tie rod if a standard height spindle is used, or with a drop spindle and 18"+ wheel sizes. If using a drop spindle with wheels smaller than 17", **do not** install the beveled tie rod spacer as it may contact the inner wheel. Two 9/16" bolt lengths are included in this suspension, 4-1/2" and 3-3/4". The longer 4-1/2" length should be used if the tie rod spacer is used and the shorter 3-3/4" should be used if the spacer is not needed. Torque the correct 9/16" bolt to 100 lb. ft.



P/S PLUMBING AND STEERING RACK:

Due to the many different engine/header combinations that can be used with this suspension, the steering shaft will need to be constructed and the plumbing routed to each application. The included center support bracket and rod end will be used as the steering shaft support once the steering shaft has been routed.

15. Create/Install the high and low pressure hoses needed to connect the rack to the power steering pump. Fitting sizes are below.

- **What rack does this system use?**

- 1997-2003 Dodge Dakota Rack & Pinion
- Rack fittings
 - Pressure: M18-1.5 O-ring to -6 AN
 - Earls 961956ERL
 - Russell 648080
 - Return: M16-1.5 O-ring to -6 AN
 - Earls 961955ERL
 - Russell 648060
- Pump Pressure fittings
 - Early pumps use a 5/8" Inverted Flare to -6 AN (≈ 1979 & earlier)
 - Russell 640380 5/8" thread inverted flare to -6 AN
 - Late pumps M16-1.5 O-Ring to -6 AN (≈1980 & newer)
 - Russell 648060
 - Earls 961955ERL

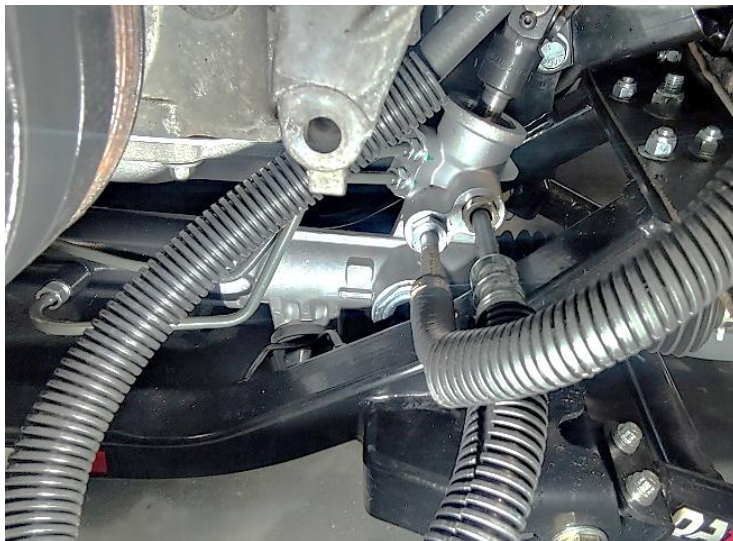

NOTE:

1980 & newer trucks with O-ring power steering hoses may be able to use stock hoses to connect to the rack. '97-'04 Dakota hoses work as well if an O-ring (1980 or newer) style pump is used. Advance Auto P/N PSH 35228 pressure & PHS 35269 return.

16. Determine and source the correct 3/4" Double D connection that will mate to the steering rack. There are multiple finishes to choose from:

3/4" Double "D" Rack Connection

<u>Manufacturer</u>	<u>Part Number</u>	<u>Finish</u>
Borgeson	014949	Steel
Borgeson	114949	Stainless
Borgeson	214949	Aluminum



Steering Column U-Joints

17. Determine the shaft length from the rack to a center u-joint. It is not recommended to do a one-piece shaft from the rack to the column so a center u-joint should be used.
18. Determine the u-joint needed to connect the new steering shaft to the steering column. Depending on the year of the truck, you will find a different spline count needed for this column joint. If the truck is using an aftermarket column the correct sized joint should be verified.
19. Assemble the three-jointed shaft you have created to check final fitment and header clearance.
20. Loosely install the CMR12 rod end onto the center support bracket with one jam nut on each side of the bracket. The upper shaft should pass through the rod end as close to the center u-joint as possible. Position the bracket onto the frame so that the steering shaft will not bind when turning.
21. Mark the holes of the bracket and drill the holes to 3/8". Mount the bracket using the 3/8" x 1-1/4" hardware with two washers and nyloc nut. Torque to 31 lb. ft.
22. Adjust the rod end in/out using the jam nuts to support the steering shaft leaving at least 1/4" of clearance with the header. Torque all u-joint set screws to the manufacturer's recommendation and the jam nuts of the center support into the bracket to secure.
23. Set the truck on the ground and turn the steering wheel lock to lock and ensure there is no interference or binding. Adjust the center support as needed.

'60-'72 3/4"-36 spline to 3/4" DD		
P/N	Brand	Finish
401-51219	Sweet	Plain Steel
401-61219	Sweet	Chrome
013449	<u>Borgeson</u>	Plain Steel
113449	Borgeson	Stainless Steel
213449	Borgeson	Aluminum

'73-'78 1"-48 spline to 3/4" DD		
P/N	Brand	Finish
401-51819	Sweet	Plain Steel
401-61819	Sweet	Chrome

'79-'87 1"DD to 3/4" DD		
P/N	Brand	Finish
401-51923	Sweet	Plain (AM)
401-51920	Sweet	Plain (GM)
401-61920	Sweet	Chrome
014952	Borgeson	Plain Steel
114952	Borgeson	Stainless Steel
214952	<u>Borgeson</u>	Aluminum



FINISHING THE JOB:

24. Double check all work before adjusting the ride height of the coil-overs and setting the truck on the ground. Re-adjust the ride height as desired. Refer to the instructions included with the shocks for suggested valve settings.
25. Install the desired brake system to the manufacturer's recommendation.

Caution: QA1 does not recommend driving the vehicle until it has been properly aligned due to major changes in suspension geometry that will affect the handling characteristics of the vehicle. A *front end alignment should be performed by a qualified alignment shop after any changes to the suspension system.*

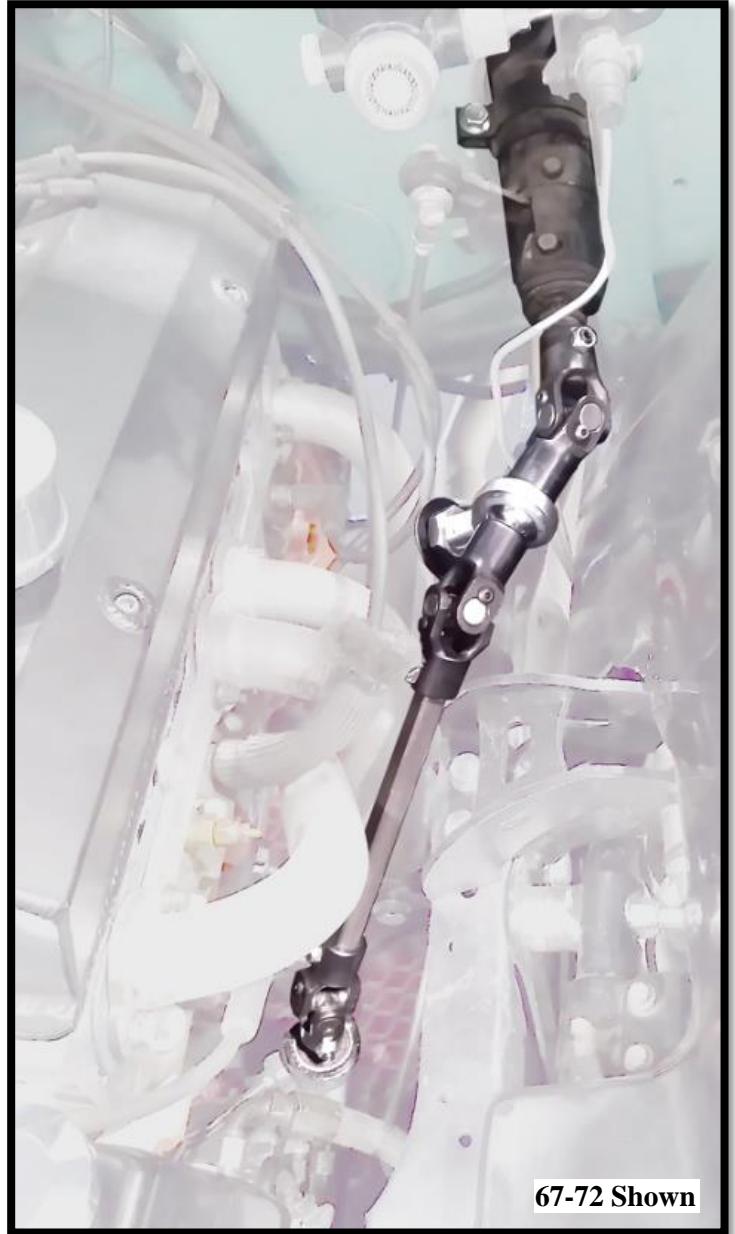

Alignment Information

These components are designed to add more caster and negative camber. It is a good idea to make the alignment shop aware of this, as the alignment shop may only try to align the vehicle to factory specs. These alignment specifications are for vehicles equipped with both QA1 upper and lower control arms. Vehicles with other configurations may not be able to achieve these alignment specifications.

Camber: $-0.5^{\circ} \pm 0.5^{\circ}$
Caster: $+8.0^{\circ} \pm 0.5^{\circ}$
Toe: $+0.2^{\circ} \pm 0.1^{\circ}$

RETROFITTING THIS CROSSMEMBER TO EXISTING QA1 SUSPENSION

Outside of these instructions, three main deviations will be needed when installing this crossmember on a truck already equipped with QA1 suspension on a stock crossmember. Follow these three deviations to complete.

LOWER CONTROL ARMS:

1. Remove the cross-shafts from the lower control arms by loosening the bolts at both ends of the shaft (**hollow arrow**). This hardware was originally installed with loctite so it is recommended to loosen these bolts with the cross-shaft still installed on the truck.
2. To remove the cross-shaft at least one of the cross-shaft bushing mounts will need to be removed, but all four of the 12 point bolts (**thin arrows**) will need to be removed. To remove the bushing mount, remove the 12 point hardware and discard. This suspension comes with new 12 point hardware for the bushing mounts. **DO NOT RE-USE THE EXISTING 12 POINT HARDWARE.** Continue on page 3 of these instructions under the LOWER CONTROL ARMS section.
3. Remove the straight and bent shock mount brackets and install the included low-profile shock mount brackets shown below and detailed on page 4, step 11.
4. If already running the QA1 52896 C10 Front Sway Bar, the included frame mounts and sway bar end links will need to be installed with this crossmember installation.

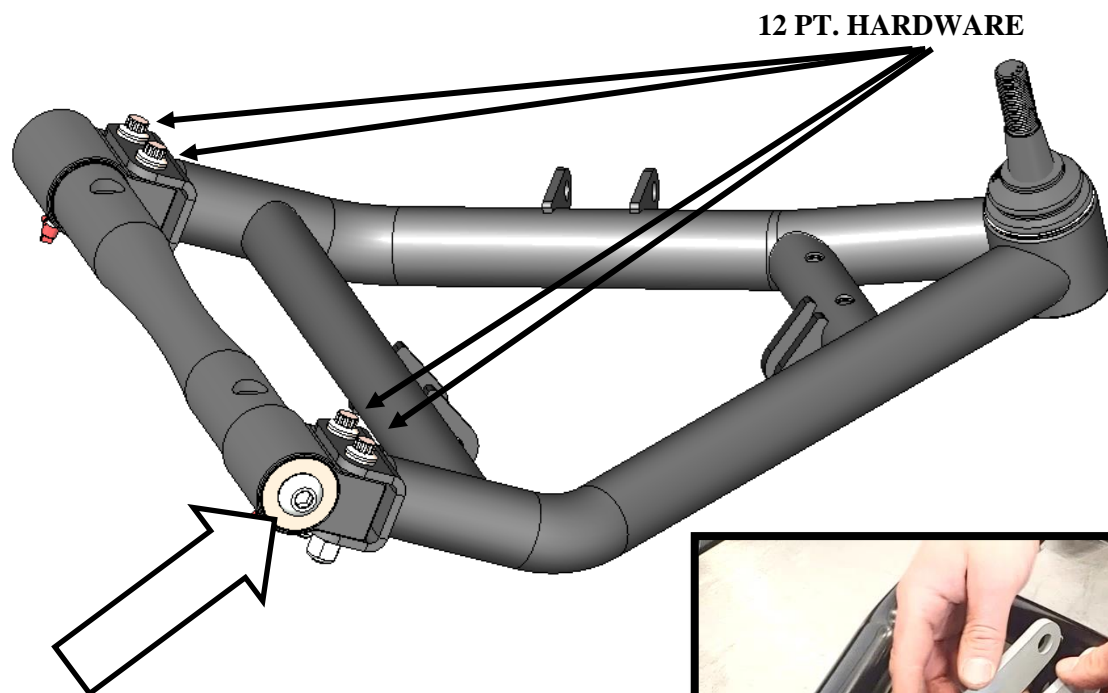

Remove the droop stops from the upper control arms and the bump stops from the lower control arms. Fill the existing threaded holes with the included 3/8" x 3/4" button head bolts.



SWAY BAR INSTALLATION:

NOTE:

The sway bar mounting bracket will need to be mounted to the truck frame dependent on the year of the truck.

'63-'72 Trucks- Mount the front hole of the sway bar mounting bracket to the existing factory hole. **(Figure 28)** With one 3/8" x 1" bolt in the front bracket slot and the factory hole, slide the bracket forward, mark and drill the rear bracket hole to 3/8".

Mount and adjust the bushing clamps to the bracket. Fasten all four connections using 3/8" x 1" hardware with two washers and one nyloc nut per connection. Torque to 31 lb. ft.

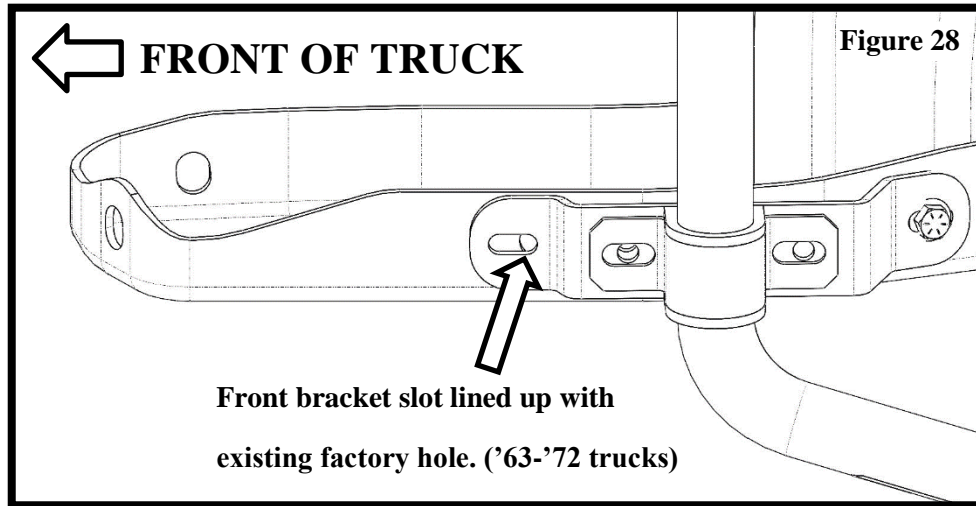

The following bracket mounting depicts the sway bar install on a '73-'87 truck

1. Mount the larger offset side of the sway bar frame bracket to the factory hole just after the upward bend using 3/8" x 1" hardware. **(Figure 29)** Two washers and one nyloc nut will be used for each connection. Torque to 31 lb. ft.
2. Insert two 3/8" x 1" bolts facing down into the bracket. **(Figure 29)**
3. Swing the bracket to be parallel with the frame rail and mark the front hole.
4. Drill the marked hole to 3/8" and fasten to the frame using 3/8" x 1" hardware with two washers and one nyloc nut. Torque to 31 lb. ft.
5. Wrap the poly bushings around the sway bar and hold in place using the included bar straps. Raise the bar up to the downward facing bolts and secure the bar to the bracket using one washer and 3/8" nyloc nut. **(Figure 30)**

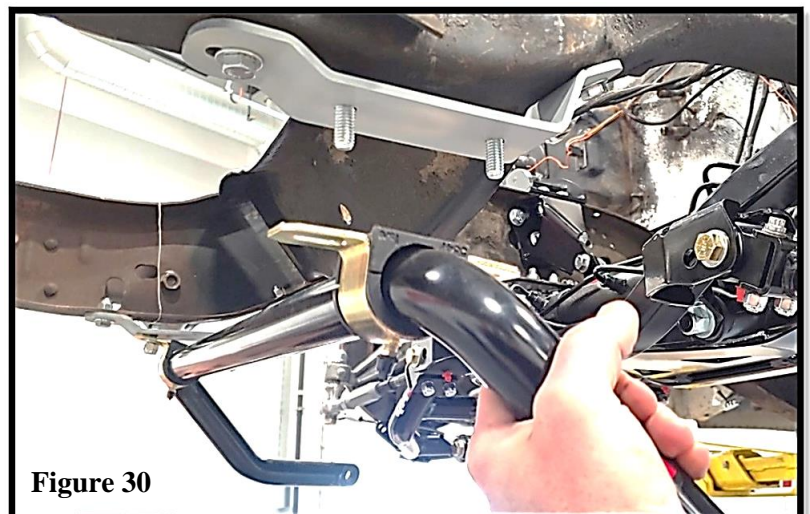

6. Assemble the two female rod ends onto the included stud with one jam nut on the non-hex side of the stud. A small amount of Loctite should be used on the fixed hex head end of the stud before installing the rod end. **(Figure 31)**
7. Insert the small diameter of the misalignment stud into the bore of the rod end with one SG8-64 spacer into the opposite side of the rod end bore. Secure with 3/8" nut. **(Figure 31)**
8. Insert the large diameter of the misalignment stud into the end of the bar on the outboard side and fasten using one 1/2" washer and nyloc nut. **(Upper portion of Figure 31)**
9. On the control arm side of the linkage, insert one SG8-67 misalignment spacer in each side of the rod end bore. **(Lower portion of Figure 32)**

10. Insert the end link into the tabs on the lower control arm and fasten with 3/8" x 2.5" hardware with two washers and one nyloc nut. Torque to 31 lb. ft.



Figure 32

11. Check the clearance of the rod end and inner tie rod at full droop. Full droop is where these items will be closest to each other. Additional clearance can be gained by sliding the sway bar frame mount forward in its slotted holes.



Figure 31

DEDICATED TECH SUPPORT

QA1 is dedicated to providing quality support and instructions. We employ passionate racers and car enthusiasts that know our products and the industry to better serve you.

CHECK US OUT ON YOUTUBE!



- Frequently Asked Questions
- Quick Tips
- Install Information
- Tuning and Repair Guides
- Other Technical Information



- [linkedin.com/company/qa1](https://www.linkedin.com/company/qa1)
- [instagram.com/qa1motorsports](https://www.instagram.com/qa1motorsports)
- [facebook.com/qa1motorsports](https://www.facebook.com/qa1motorsports)

www.qa1.net/tech

7039-315 HARDWARE KIT COMPONENTS

QTY	DESCRIPTION
2	3/4-16 JAM NUT
2	3/4-16 JAM NUT, LEFT HAND
2	5/8-11 X 3-3/4 BOLT, HEX HEAD
2	5/8-11 NUT, NYLOCK, YELLOW ZINC
2	5/8-18 NUT, SLOTTED HEX HEAD
2	5/8 WASHER, FLAT
2	5/8 WASHER, FLAT, YELLOW ZINC
2	9/16-18 X 3-3/4 BOLT, HEX HEAD, YELLOW ZINC
2	9/16-18 X 4-1/2 BOLT, HEX HEAD, YELLOW ZINC
2	9/16-18 NUT, NYLOCK, YELLOW ZINC
2	1/2-13 X 5 BOLT, HEX HEAD
6	1/2-13 X 4 BOLT, HEX HEAD
2	1/2-13 X 3 BOLT, HEX HEAD
2	1/2-13 X 1-3/4 BOLT, HEX HEAD
4	1/2-13 X 1-1/2 BOLT, HEX HEAD
2	1/2-13 X 4-1/2 BOLT, HEX HEAD
4	1/2-13 X 2 BOLT, FLAT HEAD
4	1/2-13 X 2-1/4 BOLT, FLAT HEAD
4	1/2-13 X 1-3/4 BOLT, FLAT HEAD
4	1/2-13 X 1-1/2 BOLT, CARRIAGE
30	1/2-13 NUT, NYLOCK, YELLOW ZINC
4	1/2-20 NUT, NYLOCK, YELLOW ZINC
2	1/2-20 NUT, SLOTTED HEX HEAD
46	1/2 WASHER, FLAT
8	1/2 WASHER, FLAT, (.516 ID X .875 OD X .062 THICK)
14	3/8-16 X 1-1/4 BOLT, HEX HEAD
8	3/8-24 X 2-1/4 BOLT, 12 PT
6	3/8-16 X 3/4 BOLT, BUTTON HEAD, STAINLESS
14	3/8-16 NUT, NYLOCK, YELLOW ZINC
8	3/8-24 NUT, NYLOCK YELLOW ZINC
28	3/8 WASHER, FLAT
16	3/8 WASHER, FLAT, STAINLESS, (.39 ID X .625 OD X .73 THICK)
4	7/64 X 1-1/4 COTTER PIN
2	3/4 WASHER, FLAT

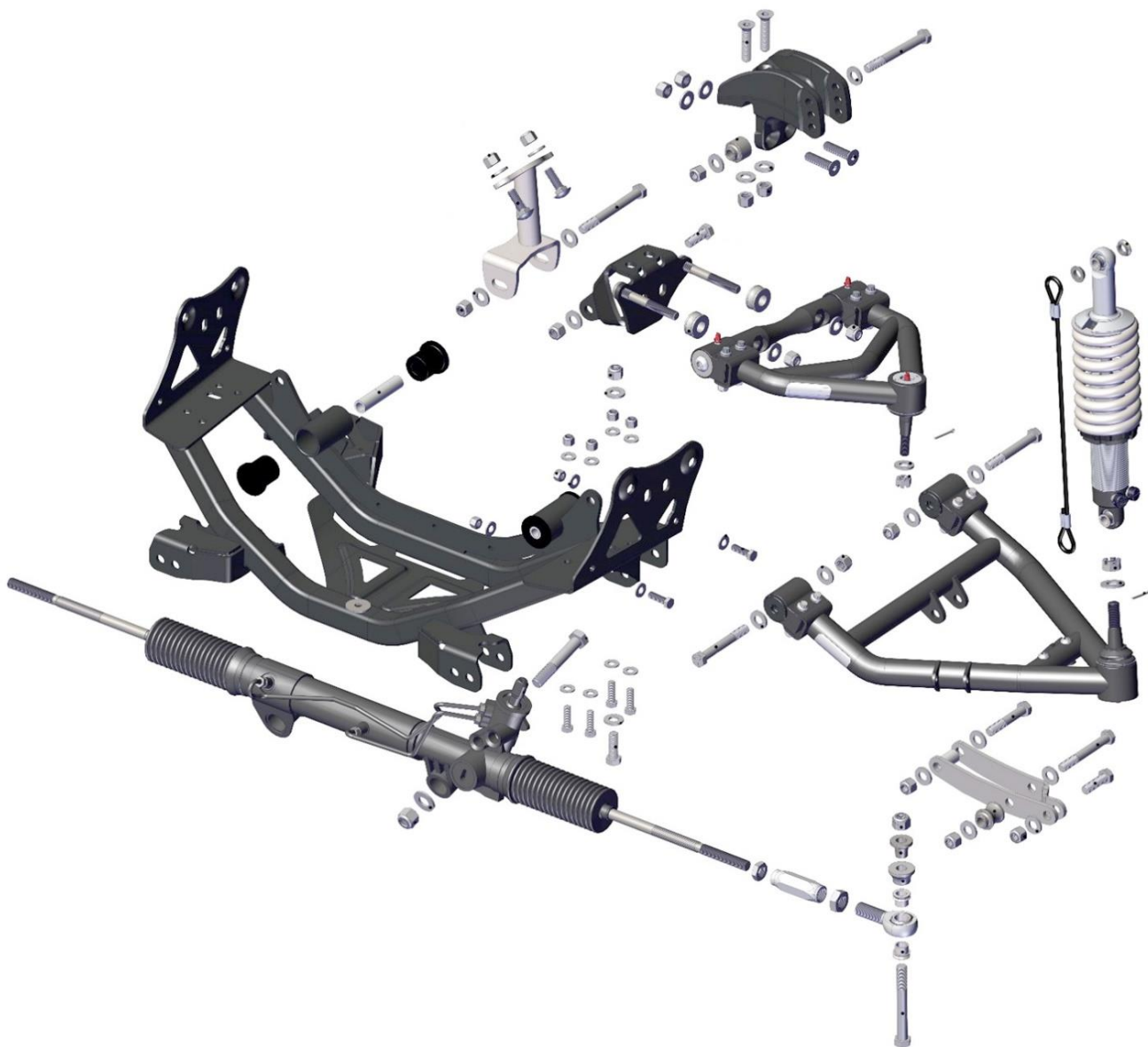

Technical Support Line: (952) 985-5675 Email: sales@QA1.net

READ ALL INSTRUCTIONS CAREFULLY AND THOROUGHLY PRIOR TO STARTING INSTALLATION. PRODUCTS THAT HAVE BEEN INSTALLED ARE NOT ELIGIBLE FOR RETURN. USE THE PROPER JACKING LOCATIONS. DEATH OR SERIOUS INJURY CAN RESULT IF INSTRUCTIONS ARE NOT CORRECTLY FOLLOWED. A GOOD CHASSIS MANUAL, AVAILABLE AT YOUR LOCAL PARTS STORE, MAY ALSO AID IN YOUR INSTALLATION.

• **DISCLAIMER / WARRANTY** •

QA1 WARRANTS THAT THE PRODUCTS WILL BE FREE FROM DEFECTS IN MATERIAL AND WORKMANSHIP FOR ONE YEAR FROM DATE OF SALE TO THE ORIGINAL PURCHASER. QA1 MAKES NO OTHER WARRANTY OF ANY KIND, EXPRESS OR IMPLIED. QA1 SHALL HAVE NO OBLIGATION UNDER THE FOREGOING WARRANTY WHERE THE DEFECT IS THE RESULT OF IMPROPER OR ABNORMAL USE, YOUR NEGLIGENCE, VEHICLE ACCIDENT, IMPROPER OR INCORRECT INSTALLATION OR MAINTENANCE, NOR WHEN THE PRODUCT HAS BEEN REPAIRED OR ALTERED IN ANY WAY. QA1'S LIABILITY IN THE CASE OF DEFECTIVE PRODUCTS SUBJECT TO THE FOREGOING WARRANTY SHALL BE LIMITED TO THE REPAIR OR REPLACEMENT, AT QA1'S OPTION, OF THE DEFECTIVE PRODUCTS.

THE USER UNDERSTANDS AND RECOGNIZES THAT RACING PARTS, SPECIALIZED STREET ROD EQUIPMENT, AND ALL PARTS AND SERVICES SOLD BY QA1 ARE EXPOSED TO MANY AND VARIED CONDITIONS DUE TO THE MANNER IN WHICH THEY ARE INSTALLED AND USED. QA1 SHALL BEAR NO LIABILITY FOR ANY LOSS, DAMAGE OR INJURY, EITHER TO A PERSON OR TO PROPERTY, RESULTING FROM THE INSTALLATION, DIRECT OR INDIRECT USE OF ANY QA1 PRODUCTS OR INABILITY BY THE BUYER TO DETERMINE PROPER USE OR APPLICATION OF QA1 PRODUCTS. WITH THE EXCEPTION OF THE LIMITED LIABILITY WARRANTY SET FORTH ABOVE, QA1 SHALL NOT BE LIABLE FOR ANY CLAIMS, DEMANDS, INJURIES, DAMAGES, ACTIONS, OR CAUSES OF ACTION WHATSOEVER TO BUYER ARISING OUT OF OR CONNECTED WITH THE USE OF ANY QA1 PRODUCTS. MOTORSPORTS ARE DANGEROUS; AS SUCH, NO WARRANTY OR REPRESENTATION IS MADE AS TO THE PRODUCT'S ABILITY TO PROTECT THE USER FROM INJURY OR DEATH. THE USER ASSUMES THAT RISK!