



DON'T FORGET

These instructions can be found in color and expandable at QA1.net

Technical Support Line: (952) 985-5675 Email: sales@QA1.net

INSTALLATION INSTRUCTIONS

QA1 P/N R130-170, R130-200, R130-250, R230-170, R230-200, R230-250

'73-'86 Chevrolet C10/ GMC C15, C1500, '87 Chevrolet/GMC R10, R1500 Rear Coil-Over Conversion W/10 bolt axle

QA1 P/N R131-170, R131-200, R131-250, R231-170, R231-200, R231-250

'73-'86 Chevrolet C10/ GMC C15, C1500, '87 Chevrolet/GMC R10, R1500 Rear Coil-Over Conversion W/12 bolt axle

QA1 P/N R132-170, R132-200, R132-250, R232-170, R232-200, R232-250

'73-'86 Chevrolet C10/ GMC C15, C1500, '87 Chevrolet/GMC R10, R1500 Rear Coil-Over Conversion W/9" Ford axle

TOOLS AND SUPPLIES REQUIRED

- Floor Jack
- Jack Stands
- Ratchet & SAE Socket Set
- Grinder and Air Chisel
- SAE Wrench Set
- Drill & Drill Bit Set
- Torque Wrench
- Anti-seize Lubricant
- Gasket maker
- Blue Locktite

Pre-Installation Notes

- This suspension will not work with 9" aluminum 3rd members.
- Installation of this system will reduce the load carrying capability of the vehicle.
- This system was designed with and can be installed with the fleet side bed on the truck; however removal of the bed may make installation easier. Step side beds should be removed. These instructions are written to install this system with the fleet side bed on the truck.
- The exhaust system will likely require modification to fit around the rear suspension.

Disassembly & Installation Instructions

1. Raise and support the rear of the truck with jack stands under the frame just ahead of the leaf spring hangers.
2. Remove the wheels and support the axle with another set of jack stands.
3. Remove the driveshaft and set a jack stand under the pinion to prevent the axle from rotating.
4. Disconnect the parking brake cables and remove them from the frame mounts.

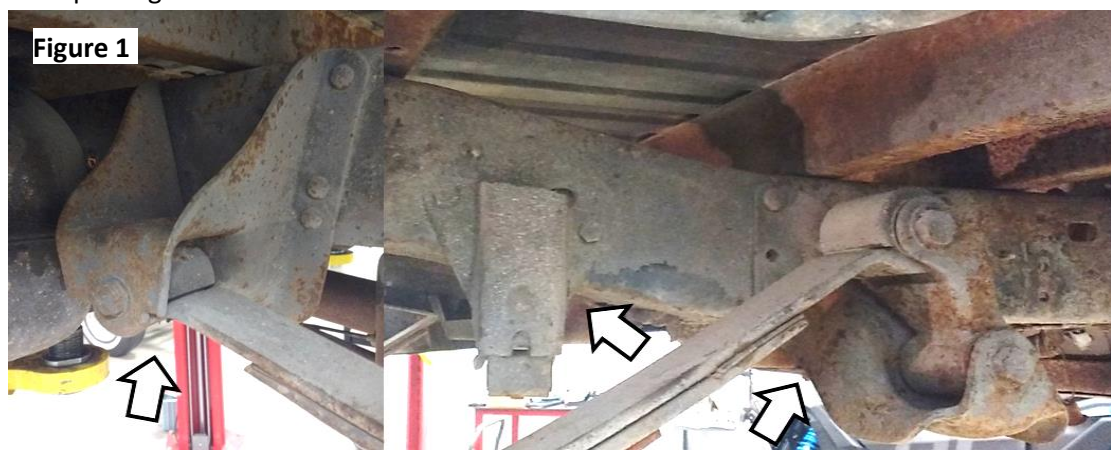

Figure 1

5. Remove the shocks and shock bolts from the frame.
6. Remove any additional exhaust hanger brackets or bolts from the frame rails that are located between the front and rear leaf spring hangers. The frame rails need to be bare to allow the C notch brackets to fit tight against the frame rails. See **Figure 1**.
7. Remove the driver's side axle U-bolts.
8. Remove the rivets from the front and rear leaf spring hangers and remove these along with the leaf pack from the truck.
9. Remove the four rivets from the bottom of the cross member located between the front leaf spring hangers. Early model trucks may have an additional support bracket for the leaf spring hanger in this location. **Figure 2**
10. '73-'83 trucks will need to have the parking brake cable mounts removed from the bottom of both frame rails. The parking brake cable mounts on '84 and newer trucks will need to have the rivets and bracket removed from the bottom of the driver's side rail.



Figure 2

11. Remove the four rivets from the factory bump stop and remove the bracket. The outside and bottom of drivers side frame rail should now be clear of brackets with only the bed bolt and nut protruding yet as shown in **Figure 3**.
12. The frame rail should be cleaned of dirt, rust and undercoating to allow the QA1 frame bracket to be bolted tightly to the outside and bottom of the frame rail.

13. Place a jack under the driver's side frame rail behind the axle to support the frame while the "C" notch is cut. Do not raise the frame off the jack stands, light pressure is all that is required.
14. Drill the factory bump stop holes out to 7/16" before bolting the "C" notch template to the frame using the factory bump stop rivet holes. Mark the "C" notch cut lines. Trucks with existing "C" notches may need to have the QA1 bracket test fit and the notch trimmed as needed. See **Figure 4**.



Figure 3

15. Remove the notch template and drill the corners of the notch to prevent stress risers and over cutting. Cut the frame notch along the marked lines. **Note: Make sure brake lines, fuel lines and wiring are out of the way and are not cut.**
16. The QA1 "C" notch bracket locates using four of the six front leaf spring hanger bolt holes on the side of the frame. The top two and bottom two holes need to be drilled to 7/16" diameter.
17. Loosely install the QA1 "C" notch bracket using four 7/16" x 1 1/4" bolts, washers and nuts.

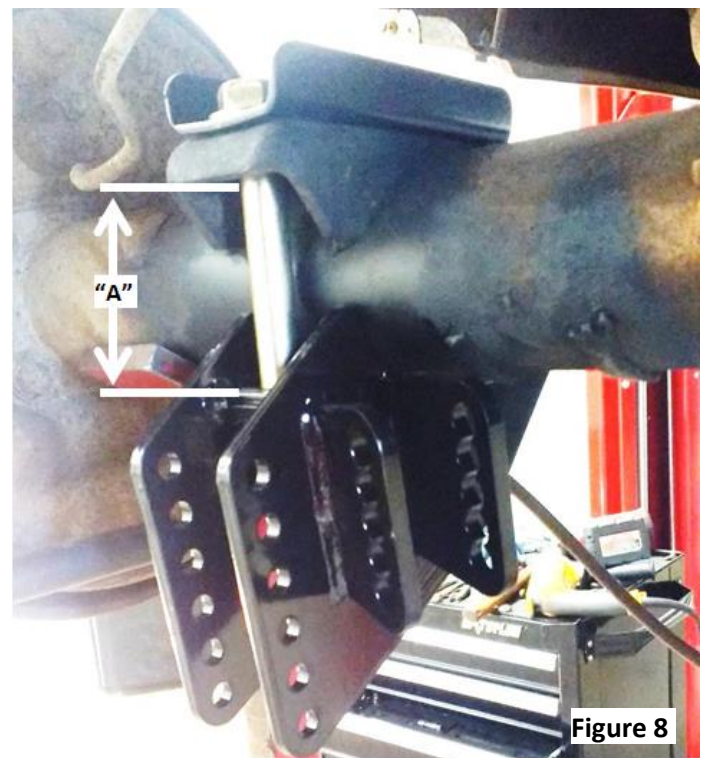

Figure 4

18. Clamp the front and rear portions of the bracket tight to the side and bottom of the frame rail and use the holes in the bracket as a drill guide. The four rivet holes for the cross member will need to be drilled to 7/16" as well. See **Figures 5 & 6**.



19. Install 7/16" x 1 1/4" bolts with washers under the head of the bolt and under the nut. Torque to 49 lb-ft.
20. Remove the factory shock mount bracket from the axle tube.
21. Clean the leaf spring pad on the axle and the area on the axle tube where the U-bolts were with a wire wheel or grinder to remove dirt and rust. Clean any dirt or rust from the leaf spring dowel hole in the pad as well. Paint as desired.
22. Set the axle pad plate on the leaf spring pad and square the edges of the bracket to the pad. Mark and drill the 5/8" holes in the pad. Starting with a 1/8" pilot hole and stepping the drill sizes up will make the holes easier to drill. See **Figure 7**.



23. Install the axle pad plate with 5/8" x 5" bolts and washers on the top side of the axle and LH axle mount on the bottom side of the axle as shown in **Figure 8**. Tighten the nuts evenly to make the "A" dimension the same on both the front and rear side of the axle. Torque to 90 lb.-ft.
24. Assemble the trailing arms by threading the JNL12S jam nuts onto the XML12 rod ends and the JNR12S jam nuts on the bushing ends. Fully thread the rod ends and bushing ends into links. See **Figure 9**.
25. Set the trailing arm length to 21-1/2" before installation. Final wheel base adjustments should be made once the truck is at ride height.

BALLOON #	ITEM #	DESCRIPTION	QTY
1	9037-279	WELDMENT, TRAILING ARM	2
2	JNR12S	NUT, JAM 3/4-16 RH	2
3	JNL12S	NUT, JAM 3/4-16 LH	2
4	XML12	ROD END, 3/4-16 LH MALE	2
5	7039-157	BUSHING END	2
6	9033-317	SLEEVE, .56" ID X .75" X 1.88"	2
7	9033-116	CAP, GREASE ZERK	2
8	9032-169	BUSHING	4
9	SG12-106	SPACER, HM	4
10	7039-230	HARDWARE KIT, TRAILING ARM	2

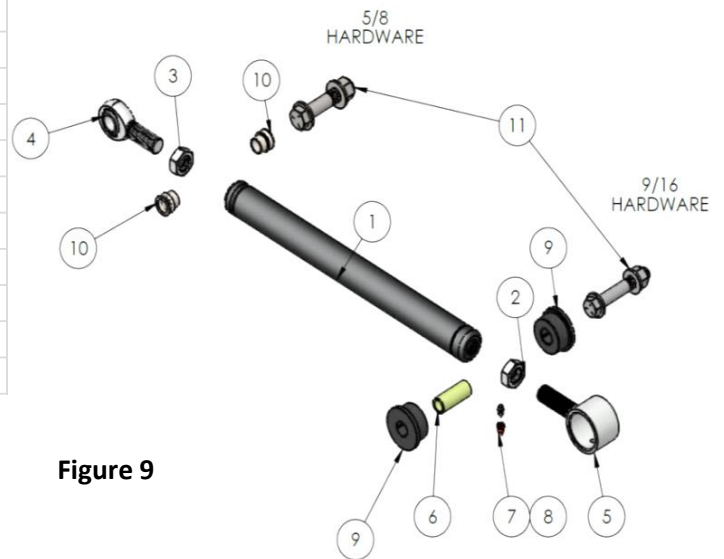

26. Install the links' bushing end on the frame bracket with the grease fitting pointed down, using a 9/16" x 4" bolt, washers and nut. Install the rod end on the axle bracket with 1/2" x 4" bolts and high misalignment spacers, P/N SG12-106 in the center hole.

27. Repeat steps 7 through 25 for the passenger side. The factory brake hose mount will need to be removed and reused once the QA1 frame bracket is installed. See **Figure 10**.

28. If the factory parking brake is being retained, mount the included brackets to the bottom of the QA1 frame bracket/ C-notch. 1984 and newer trucks will use one bracket on the drivers' side. The parking brake cable mount bolts on using two of the bolts near the trailing arm mounts as shown in **Figure 11a**.

29. '73-'83 trucks using the factory parking brakes will need one bracket mounted on each frame rail as shown in **Figure 11b**. The vertical portion of the bracket will be towards the rear or the truck using the first hole in the upward slope rearward of the trailing arm support.

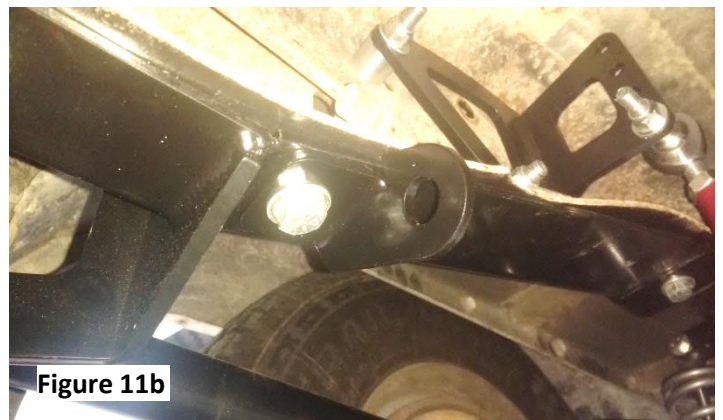

Torque Arm Installation

Note: for 9" Ford axles refer to pages 10 & 11

1. Remove the rear differential cover and drain the fluid. Clean the diff cover mount surface of the gasket material, dirt and corrosion. The QA1 cover should sit flat against the differential housing.
2. Verify the QA1 differential cover has the correct number of mounting holes for the differential in the truck. Apply gasket maker to the differential, install the QA1 cover with the included bolts with Blue Locktite on the threads. Torque to 20 lb.-ft. See **Figure 12**.
3. Insert the torque arm cross member frame plate into the frame rail and clamp it as shown in **Figure 13**. **This will be used as a drill guide.** For long box trucks, the bracket needs to be centered under the 2nd from the front bed cross rail. On short box trucks, the bracket should be mounted up against the cab mounts. The edge of the bracket needs to be 8 3/8" forward of the most forward C-notch frame bracket mounting hole. This is the length of the C-notch template. **Figure 14**



Figure 12



Figure 14

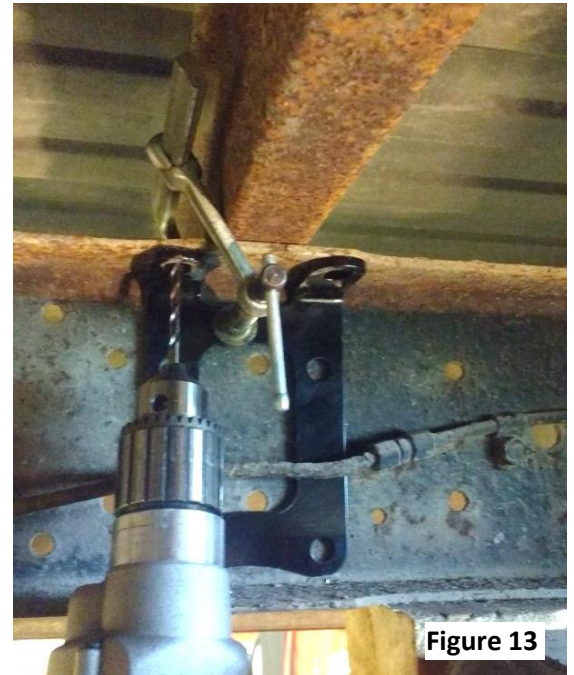

Figure 13

Note for short box trucks with driver's side fuel tanks: The bracket for the fuel cross over lines will need to be trimmed on the passenger side to clear the torque arm cross member.

4. Once the bracket is in place, drill one 1/8" pilot hole at the edge of each slot closest to the frame rail.
5. Remove the bracket and enlarge both holes to 7/16". Stepping the drill bit size to 1/4" then to 7/16" will help prevent the bit from walking. Repeat steps 1 through 3 on the other frame rail.
6. Turn the brackets around and set the tabs on the top side of the frame rails. Install and snug the 7/16" x 1 1/4" bolts with washers and nuts.



7. Loosely install the torque arm cross member with 7/16" x 1 1/4" bolts, washers and nuts. Clamp the flange on the cross member tight to the bottom flange on the frame and drill the 7/16" holes. Install the remaining 7/16" bolts with washers and nuts. Torque the nuts to 49 lb.-ft. See **Figure 15**.
8. Assemble the torque arm with the included hardware as shown in **Figure 16**.
9. Install the torque arm in the truck using the 3/4" x 4" bolt nut and washers on the front mount. The bolt should be inserted from the center of the truck facing out to avoid any interference with the driveshaft as shown in **Figure 15**.
10. Assemble the torque arm support brace by first threading the JNR8S jam nut onto the XMR8 rod end and the JRL8S jam nut onto the XML8 rod end. Fully thread the rod ends into the adjuster sleeve.

ITEM #	DESCRIPTION	QTY.
9037-765	WELDMENT, TORQUE ARM	1
XMR10-12	ROD END 5/8-3/4 MALE RH	2
XFR12	ROD END 3/4 FEMALE RH	1
JNR12S	JAM NUT 3/4-16 RH	3
AS12-12	LINKAGE ADJUSTER STEEL 3/4-16	1
SG104	SPACER ROD END SS	2
7039-157	PANHARD ROD, SHORT END WELDMENT	1
9032-169	BUSHING, URETHANE	2
9033-317	SLEEVE, .563" ID X .75" OD X 1.88"	1
9023-116	CAP, GREASE ZERK	1
9023-119	FITTING, ZERK 1/4-28 STRAIGHT	1
7039-232	HARDWARE KIT, TORQUE ARM	1

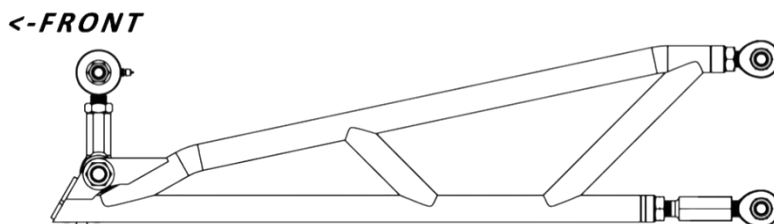

Figure 16

11. Install the torque arm support brace on the frame mount and torque arms using SG8-64 spacers and both sides of the rod ends and the 3/8" x 2 1/2" bolts washers and nuts. Adjust the length of the support brace until the torque arm front link is vertical from left to right. See **Figure 17**.



Figure 17

Panhard Bar & Shock Installation

1. Assemble the panhard bar support rod by threading the JNR12S jam nut onto XMR10-12 rod end and JNL12S jam nut onto the XML10-12 rod end. Fully thread both rod ends into the Support brace.
2. Thread the JNR12S jam nut onto the XMR12 rod end and thread into AS12-12 linkage adjuster.
3. Thread the rod end and linkage adjuster into the panhard bar.
4. Install the panhard bar support brace on the driver's side frame bracket with a SG104 spacer on each side of the rod end and the 5/8" x 2 1/2" bolt, nut and washers. Adjust the length of the support brace until the bolt holes line up by holding the rod end and turning the tube to ensure equal thread engagement on each rod end when adjusting the length. **Figure 18**

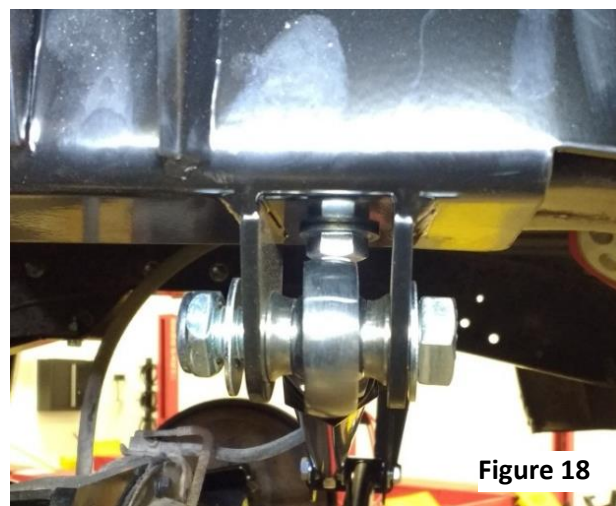

Figure 18

5. Install the panhard bar and panhard bar brace on the passenger side frame bracket with the support brace towards the rear of the vehicle using the holes in the center of the adjustment range. The 5/8" x 4 1/4" bolt will be used with a SG104 spacer on each side of the rod end and a flat washer between the spacer and the panhard bar bushing. **Figure 19**

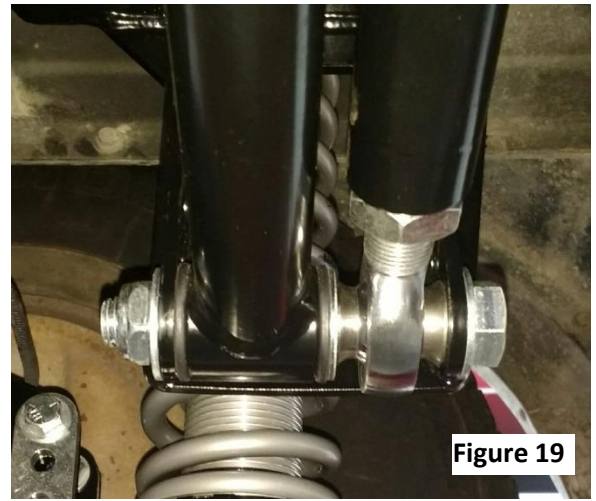

Figure 19

6. Install the panhard bar on the axle bracket using the 5/8" x 3" bolt, washers and nut. A SG108 spacer will be used on each side of the rod end. Adjust the length of the panhard bar until the bolt holes line up by holding the rod end and turning adjuster to ensure equal thread engagement on the rod end and adjuster when adjusting the length. **Note:** The panhard bar height will need to be adjusted once the truck is set at ride height. **Figure 20**

7. Install the shock mount brackets on the outside of the axle brackets with the 3/8" x 1" bolts with a washer under the head of the bolt and the nut as shown in **Figure 21**. This is the lowest position these should be installed. The shock mount position can be adjusted up to raise the vehicle or lowered to lower the vehicle ride height. There should always be at least one open hole between the shock mount bolts. Torque the bolts to 30 lb. ft.

BALLOON #	ITEM #	DESCRIPTION	QTY.
1	9037-566	WELDMENT, BRACE BAR	1
13	9037-770	WELDMENT, PANHARD BAR	1
3	7039-245	INSTALL KIT FOR PANHARD BAR	1
4	XMR10-12	ROD END (X) ENDURA ALLOY HT	2
5	JNR12S	JAM NUT, 3/4-16 RH	2
6	JNL12S	JAM NUT, STEEL 3/4-16 LH	1
7	AS12-12	LINKAGE ADJUSTER STEEL 3/4-16	1
8	SG104	SPACER ROD END SS	4
9	SG10-86	High Misalignment Spacer, SS	2
10	9032-395	BUSHING, .875	2
11	9033-457	SLEEVE .625" ID x 0.875" OD x 1.75"	1
12	XML10-12	ROD END (X) ENDURA ALLOY HT	1
13	7039-233	HARDWARE KIT, PANHARD BAR	1
14	-	WASHER, 5/8, SAE	5
15	-	BOLT, 5/8"-11 X 2.5"	1
16	-	BOLT, 5/8"-11 X 4.25"	1
17	-	JAM NUT, NYLOCK, 5/8-11	2
18	-	WASHER, SAE, 1/2	2
19	-	NUT, NYLOCK, 1/2-13	1
20	-	BOLT, 1/2-13 X 2.75"	1
21	9093-122	DECAL, SUSPENSION DECAL, USA	1



8. Refer to coil-over shock instructions to assemble spring onto shock. Install the assembled shock and spring into the upper shock mounts with the 1/2" x 2 1/2" bolts, nuts and washers. Torque to 50 lb. ft.

9. Install the lower shock eyelet into the shock mounts with the 1/2" x 2 1/2" bolts, nuts and washers. Spacer P/N 9033-430 will need to be installed on either side of the spherical bearing on the lower shock mount as shown in **Figure 22**. Torque to 50 lb. ft.



Figure 20

10. Reinstall the driveshaft if removed.
Note: Be sure to verify the driveshaft to cross member clearance with a one piece driveshaft and modify the cross member as needed.
11. If the brake system has been opened, bleed the brakes before driving.
12. Reinstall wheels and tires.



Figure 21



Figure 22

Adjustments

1. With the shocks installed, adjust the shock length with the threaded adjustment until the shock measures 14"-15" when the suspension is loaded. Then use the adjustable mounts to set the truck at the desired ride height. **Figure 21** shows the lowest position of the shocks mounts. There should always be at least one hole between the mounting bolts.

Note: The suspension should be unloaded when making any ride height changes to prevent damage to the shocks.

2. Adjust the trailing arm height to make the trailing arms level when the truck is sitting at ride height.
3. Adjust the trailing arm length to center the wheels in the wheel openings.
4. Adjust the panhard bar height so the panhard bar is level
5. Once the panhard bar is level, use the adjuster on the panhard bar to center the axle under the truck by measuring from the wheel rim to the frame on each side of the vehicle. Once the panhard bar length is set, tighten all bolts and jam nuts.
6. Using the adjuster on the torque arm, adjust the pinion angle and tighten the jam nuts on the adjuster. Changing the torque arm mounting height on the cross member and/or changing the ride height of the vehicle will change the pinion angle.
7. Check **all** mounting hardware for tightness.
8. A four wheel alignment should be performed by a capable alignment shop.



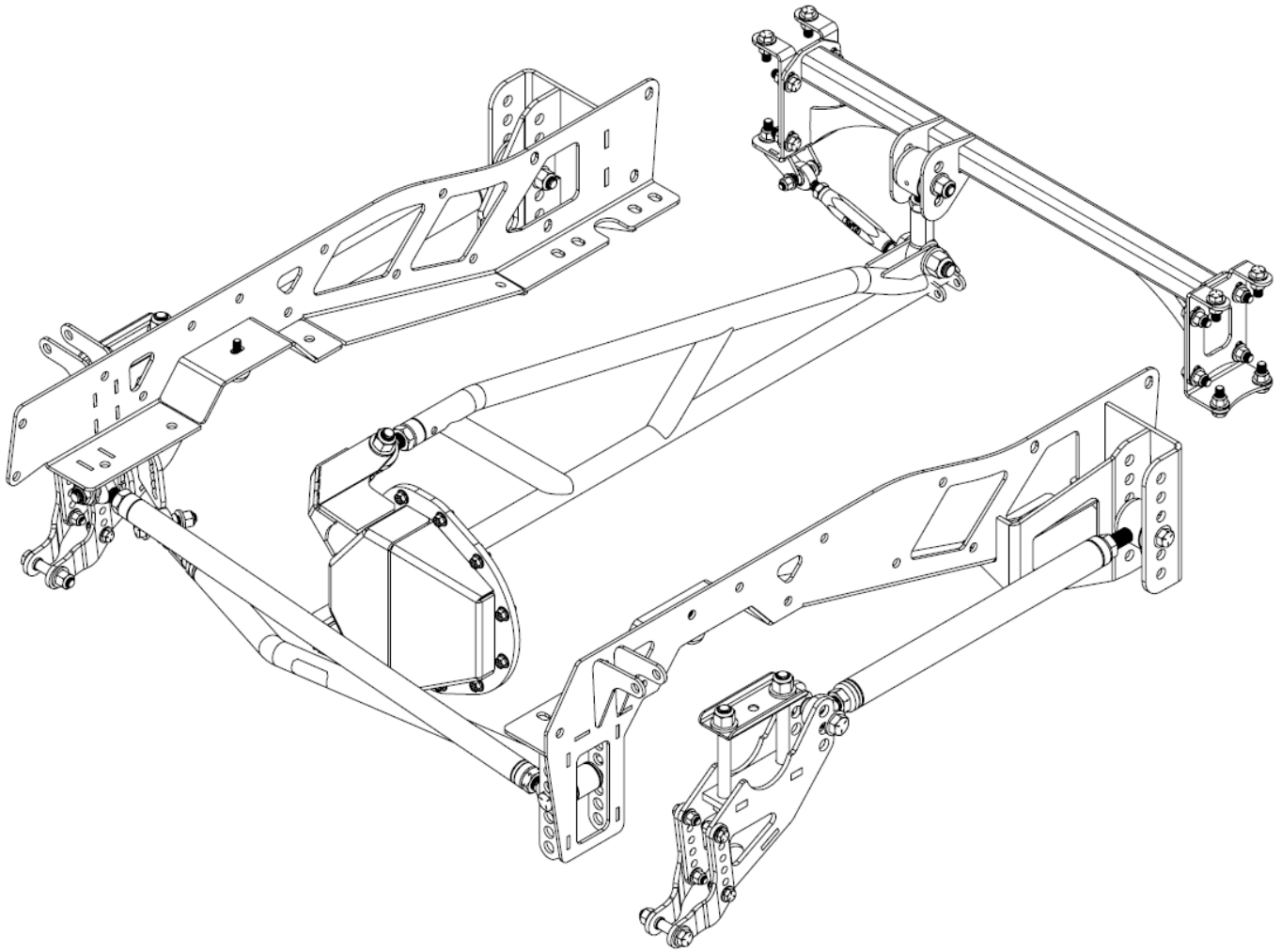

Converting Your 10/12 Bolt QA1 Suspension To Work With A 9" Axle-

Future upgrades to a 9" axle made easy by ordering the following parts:

<u>PART NUMBER</u>	<u>DESCRIPTION</u>	<u>QUANTITY NEEDED</u>
<u>9037-735</u>	<u>Nut, Shouldered 3/8-24 x 5/8 Hex</u>	<u>4</u>
<u>9037-679</u>	<u>Plate, Pinion Torque Arm Mount</u>	<u>1</u>
<u>7039-232</u>	<u>Hardware Kit, Torque Arm</u>	<u>1</u>
<u>9037-906</u>	<u>Double Shear, 9 inch</u>	<u>1</u>
<u>9037-691</u>	<u>Torque Arm Weldment</u>	<u>1</u>

≡



Technical Support Line: (952) 985-5675 Email: sales@QA1.net

Torque Arm mounting for 9" Axle

This system is designed for use with 9" axles built as direct bolt in units for '73-'87 C10's with leaf springs.

1. Mount the torque arm bracket (#8) to the differential by removing the four drivers' side nuts from the front side of the differential. **(Figure 23)** Mount torque arm bracket using shouldered nuts from the Torque Arm Hardware Kit (p/n 7039-232) Using Loctite blue, torque to 37 lb. ft. **(Figure 24 & 25)**



Figure 23

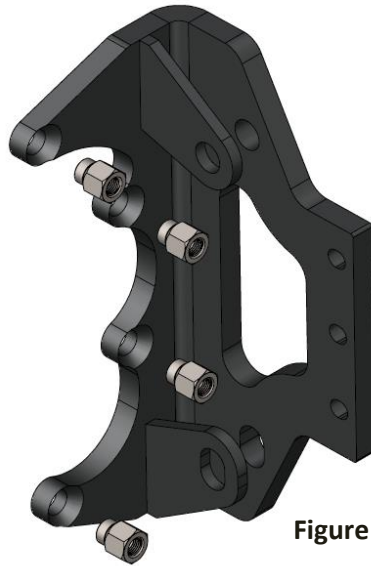

Figure 24

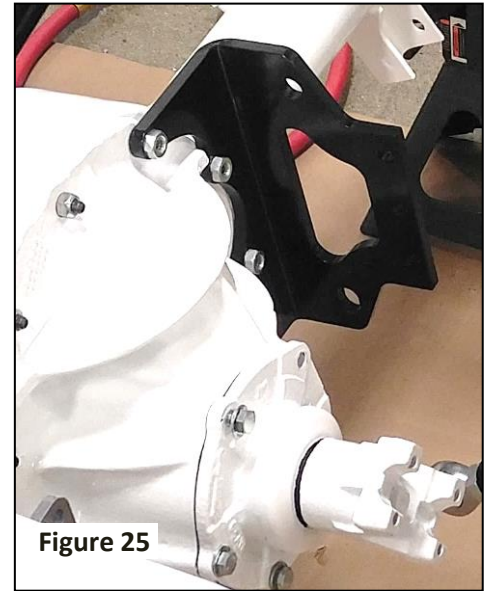
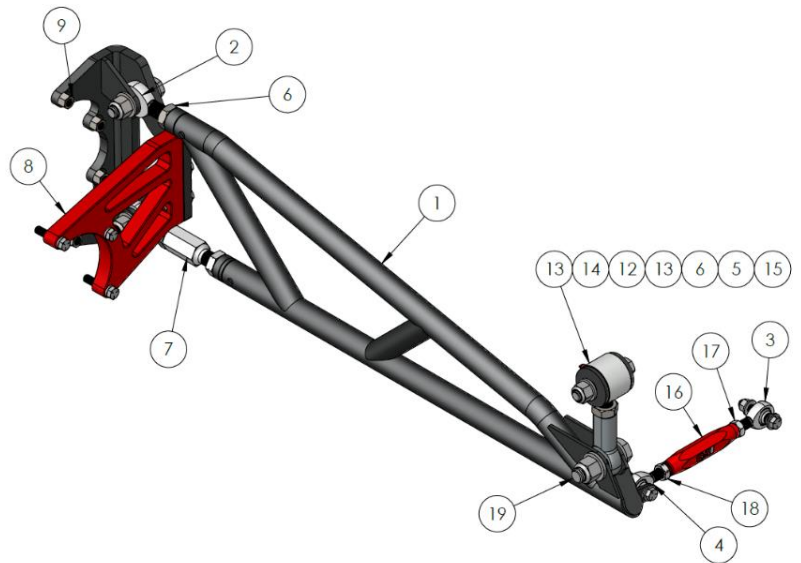

Figure 25

BALLOON #	ITEM #	DESCRIPTION	QTY.
1	9037-691	WELDMENT, TORQUE ARM	1
2	XMR10-12	ROD END (X) ENDURA ALLOY HT	2
3	XMR8	ROD END (X) ENDURA ALLOY HT	1
4	XML8	ROD END (X) ENDURA ALLOY HT	1
5	XFR12	ROD END (X) ENDURA ALLOY HT	1
6	JNR12S	JAM NUT, 3/4-16 RH	3
7	AS12-12	LINKAGE ADJUSTER STEEL 3/4-16	1
8	9037-679	BRACKET, FRONT PINION MOUNT	1
9	9037-735	NUT, SHOULDER, 3/8-16 X 5/8 HEX	4
10	SG8-64	HIGH MISALIGNMENT SPACER, .5" OD	4
13	7039-157	Panhard Rod Asm., Short	1
12	9032-169	Bushing, Energy 2042G	2
13	9033-317	Sleeve, .56" ID X .75" OD X 1.88"	1
14	9023-116	CAP, GREASE ZERK	1
15	9023-119	GREASE ZERK, 1/4-28	1
16	9033-459	SLEEVE, .875" HEX ALUMINUM ANODIZED	1
17	JNR8S	Jam Nut, Right Hand Thread	1
18	JNRLS	Jam Nut, Left Hand Thread	1
19	7039-232	HARDWARE KIT, TORQUE ARM	1
20	9037-906	WELDMENT, REAR, 4 BOLT	1



2. Install XMR10-12 rod end (#2) with JNR12S jam nut (#6) into rear upper connection of torque arm. Screw rod end fully into torque arm.
3. Install AS12-12 male to female linkage adjuster (#7) with left hand jam nut into lower torque arm connection. Thread in the remaining XMR10-12 rod end (#2) with jam nut. This linkage adjuster will be your pinion angle adjustment.
4. Install the rear torque arm connection to the torque arm bracket using 5/8" x 2.75" bolts, two washers per connection, and nylock nuts. Torque to 90 lb. ft.
5. Install the two bushing halves (#12) then 5/8" sleeve (#13) into the large bushing end for the front torque arm assembly.

6. Install a 3/4" jam nut (#6) onto the male threads of the large bushing end (#13) followed by the XFR12 female rod end (#5).
7. Install assembled rod end into front torque arm connection using 3/4" x 2.75" bolt, two 3/4" washers, and 3/4" nylock nut. (Figure 27)
8. Install 1/2" right hand threaded jam nut (#19) onto XMR8 rod end (#3). Screw the rod end into right hand threaded red aluminum adjuster sleeve (#18).
9. Install left hand XML8 rod end (#4) with JNL8S left hand jam nut (#20) into the LH threaded end of the adjuster sleeve (#18).



Figure 27

HARDWARE KIT, TORQUE ARM, 73-87 C10 WITH 9" AXLE		
1st Description	2nd Description	Qty.
BOLT, 9/16-12 X 3.25"	GRADE 5, CLEAR ZINC	1
NUT, NYLOCK, 9/16-12	GRADE 5, CLEAR ZINC	1
WASHER, 9/16, SAE	GRADE 5, CLEAR ZINC	2
BOLT, 3/4-10 X 2.75"	GRADE 5, CLEAR ZINC	1
NUT, NYLOCK, 3/4-10	GRADE 5, CLEAR ZINC	1
WASHER, 3/4, SAE	GRADE 5, CLEAR ZINC	2
BOLT, 5/8-11 X 2.75"	GRADE 5, CLEAR ZINC	2
NUT, NYLOCK, 5/8-11	GRADE 5, CLEAR ZINC	2
WASHER, 5/8, SAE	GRADE 5, CLEAR ZINC	6
BOLT, 3/8-16 X 2.25"	GRADE 5, CLEAR ZINC	2
BOLT, 3/8-16 X 1.375"	GRADE 5, CLEAR ZINC	3
BOLT, 3/8-16 X 1.75"	GRADE 5, CLEAR ZINC	3
NUT, NYLOCK, 3/8-16	GRADE 5, CLEAR ZINC	2
WASHER, 3/8, SAE	GRADE 5, CLEAR ZINC	7
WASHER, 3/8	MS-51412-26, ZINC	3

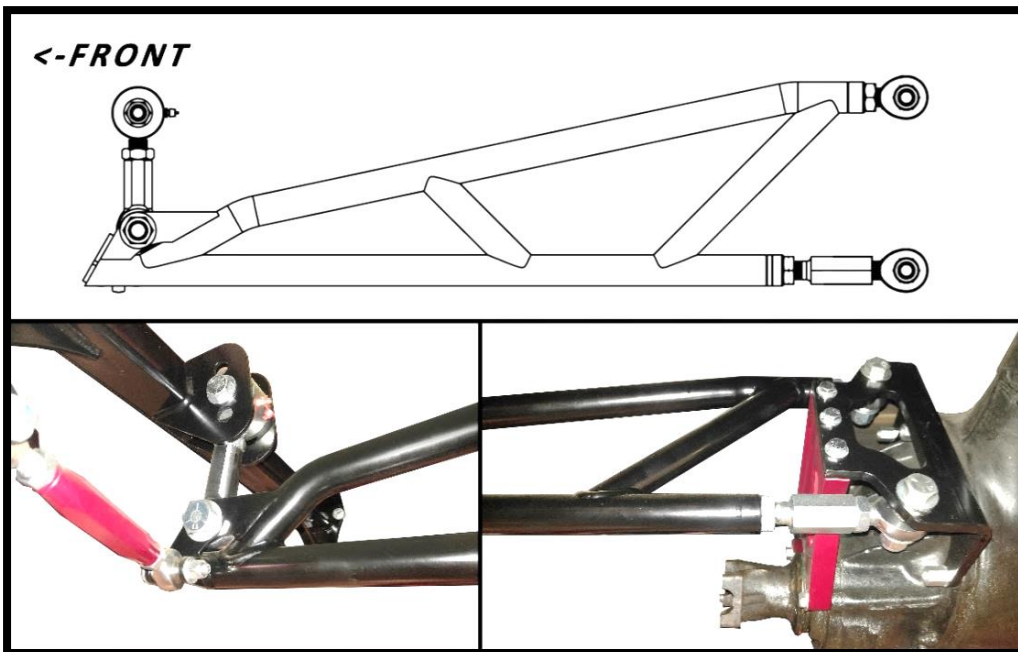

Figure 28

10. Install the assembled adjuster sleeve (#18) into the front side bracket of the torque arm with two 1/2" SG8-64 High Misalignment Spacers (#12) installed in both sides of the rod end. **(Figure 28)** Secure to torque arm using 3/8" x 2.25" bolt, two washers, and nylock nut.
11. Install the red anodized Front Pinion Mount to torque arm bracket using 3/8" x 1.25" bolts and washers. Bolt the Pinion Mount to differential using three 3/8" x 1.75" bolts and washers.
(Figure 29)
12. Continue with the "Panhard Bar & Shock Installation" on page 6.

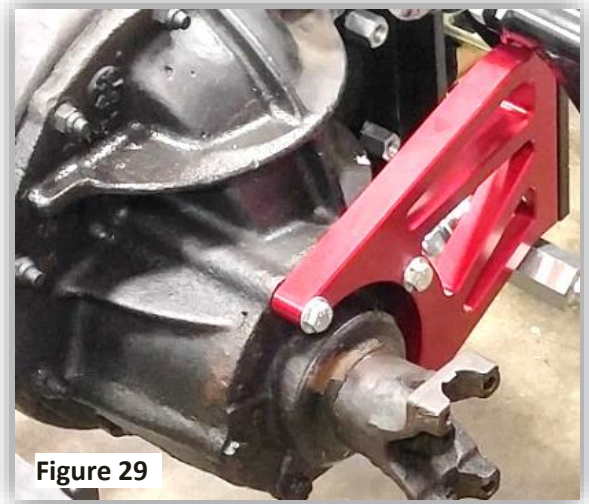
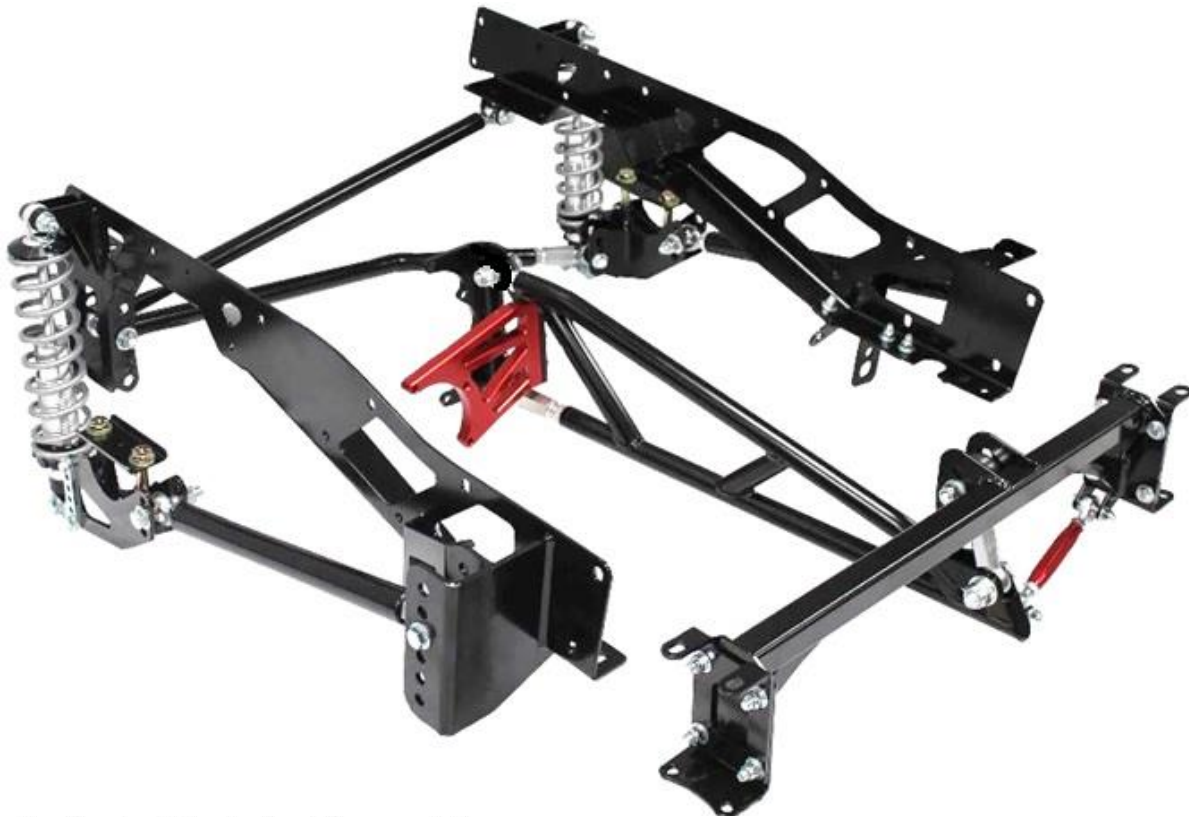

Figure 29



Dedicated Technical Support Team

QA1 is dedicated to providing quality support and instructions. We employ passionate racers and car enthusiasts that know our products and the industry to better serve you.

Give our tech support line a call at **1.800.721.7761**

Visit online at www.QA1.net/tech or www.YouTube.com/QA1Tech for:

- Frequently Asked Questions
- Quick Tips
- Install Information
- Tuning and Repair Guides
- Other Technical Information

Our technical support and order lines are open **Monday – Friday, 8 am to 5 pm CST.**

