



These instructions can be found in color and expandable at QA1.net

Technical Support Line: (952) 985-5675 Email: sales@QA1.net

INSTALLATION INSTRUCTIONS

QA1 P/N 52620-x400, 52620-x500, 52620-x600, 52621-x400, 52621-x500, 52621-x600
'65-'79 F100 & '75-'79 F150 Front Coil-over Suspension System

TOOLS AND SUPPLIES REQUIRED

- Floor Jack
- Two (2) Jack Stands
- Drill with 3/8" & 1/2" drill bits
- SAE Wrench Set
- Anti-seize
- Ratchet & SAE Socket Set
- Torque Wrench
- Grinder or Air Chisel

ADDITIONAL PARTS NOT SUPPLIED WITH KIT

- 79-81 Camaro brake kit
- QA1 Engine Mounting Plates
- Steering shaft & DD u-joint connections
- Aftermarket steering column (recommended)
- New Steering & Brake Lines
- Front wheels with 5 x 4-3/4" bolt pattern or wheel adapters to original 5 x 5-1/2" bolt pattern

Pre-Installation Note

A grinder or air chisel is recommended for removal of factory rivets.

Disassembly Instructions

1. Remove the hood and front bumper, then remove front clip.
2. Remove the engine and transmission (**Figure 1**)
3. Raise the vehicle and support the frame 5" behind front cab mounts with jack stands on a stable surface. (**Figure 6 & 8**)
4. Remove the wheels, brakes, shocks, steering box, and 3 bolt steering shaft joint.
5. Unbolt and remove the twin I-beams and trailing arms. (**Figure 2**)



Figure 1

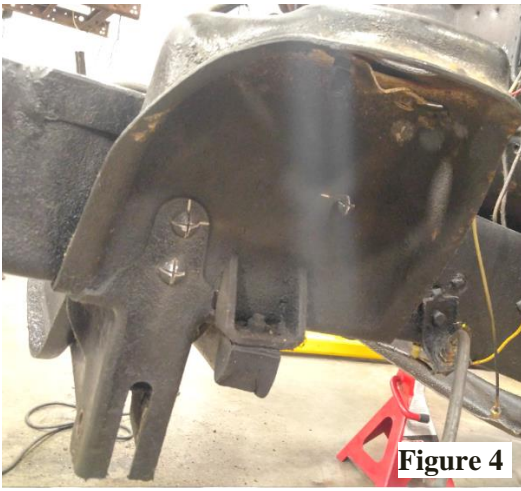

Figure 2



Figure 3

NOTE: It is strongly recommended to brace the front of the frame (**Figure 3, 6, & 8**) and re-install transmission cross-member before removing factory cross-members.



6. Slot and remove the rivets from spring pockets, I-beam mounts, engine cross-member, brake line support brackets, and cross-member at cab mounts **(Figure 4)**. Do not remove any rivets supporting the cab mounts at the rear cross-member. There should be no rivets in the frame forward of the cab mounts when complete. **(Figure 8)**

7. Cut engine cross-member flush with the frame rails and remove. The remaining three-sided portion of the engine cross-member remaining in the frame rails does not need to be removed. **(Figure 5&6)**

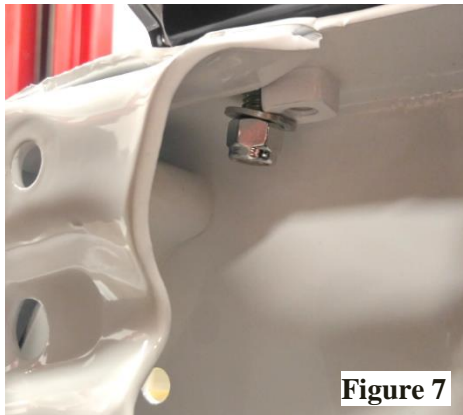
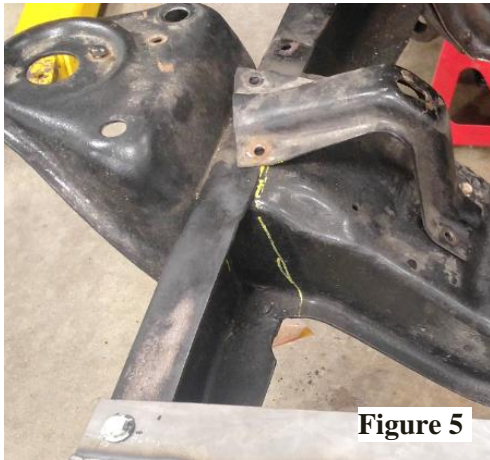

NOTE: If your inner drivers side frame rail has a threaded square nut welded to the frame **(Figure 7)** it will need to be removed. There may be a weld bead in this area that will need to be ground down to allow the bracket in step 4 of the install portion to sit flat on the inside of the frame. These welds should be ground flat if found.

8. All frame rivets from the cross-member at cab mounts forward should be removed at this time. **(Figure 8)**
9. Clean the frame of dirt, rust and undercoating to allow the QA1 parts to fit tightly to the frame. Paint as desired.

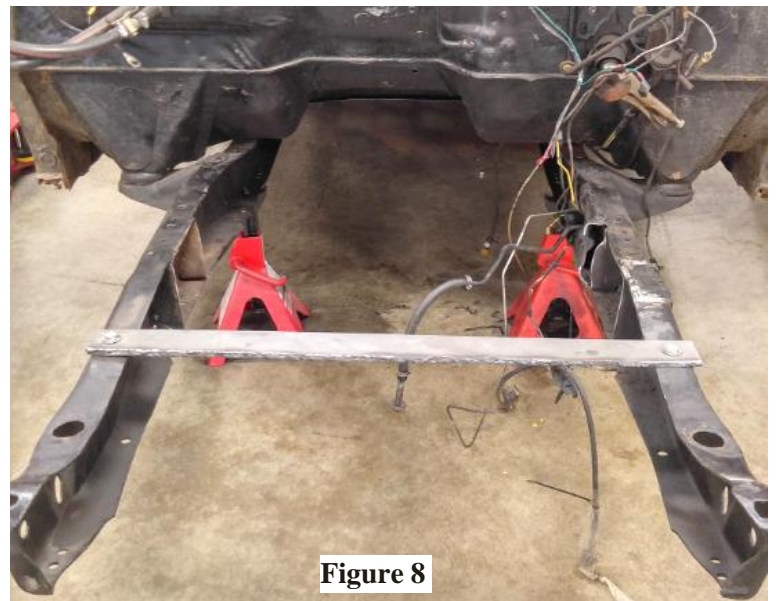

Installation Instructions

SPECIAL INSTRUCTIONS FOR '73-'79 TRUCKS ONLY

If your truck is a 1965-1972 continue onto page 4

The lower frame rails on the 1973-1979 trucks have a downward curvature from the factory that will need to be straightened to mate with the QA1 lower crossmember.

Using a large pipe wrench or similar leveraging device, evenly straighten the frame rail in small, even steps. When complete, the frame in the marked areas that contacts the crossmember should be flat. The section of frame between the marked areas does not need to be completely flat. It is recommended that the rear pivot point of the control arm be checked for frame clearance before completing the suspension install.

Complete this process for both driver and passenger frame rails.

QA1 does not recommend heating the frame to complete this step.



Hardware Note:

The last page of these instructions is a hardware guide. This suspension system comes with two different O.D. 1/2" washers (#29 and #30). The smaller O.D washers will install touching QA1 Parts and the larger O.D. washers are installed touching the original frame. Use the below washers to secure both QA1 cross-members to the frame.

Balloon #	Part #	Description	Qty Included
*29	9005-228	WASHER, FLAT 1/2" SAE	20
*30	9005-251	WASHER, FLAT 1/2"	42

(*) parts in General Hardware Kit part number 7039-225
 (**) parts in Specialty Hardware Kit part number 7039-226

1. Pre-drill the existing eight holes in the frame where the engine cross-member was removed with a 1/2" drill bit. Six holes will be on the side of the frame and three on the underside of the frame. **(Figure 9)**
2. Pre-drill the existing hole on the underside of the frame located directly under the cab mounting bracket to 1/2". **(Figure 10)**

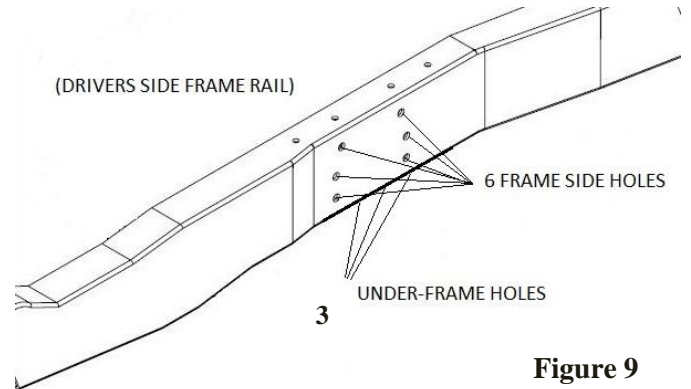

Figure 9



Figure 10

3. Set cross-member brace bracket (#11) inside frame, lining up the three mounting holes on the **Drivers Side** with the existing **rear** three holes in the frame box and one existing under-frame hole. Line up the bracket on the **Passenger Side** with the three existing **front** holes. These brackets are not left/right specific. **(Figure 11)**



Figure 11

4. Mount the QA1 lower cross-member (#2) to the frame and inner frame brace bracket using 1/2"x 1-1/2" (#28) hardware using ONLY the two lower side bolt holes and all existing underside mounting hardware to evenly draw the cross-member to the frame. The upper two side mounting holes will be used to secure the upper cross-member to the lower cross-member further in the instructions. Drill the two holes in the bottom of the frame rails for the QA1 cross-member and fasten with same 1/2"x1.5" hardware. (#28) **(Figure 12 & 13)**



Figure 12



Figure 13

HARDWARE IN LOWER TWO HOLES ONLY. UPPER HOLES USED IN NEXT STEP

NOTE: Do not tighten hardware until both upper and lower cross-members are installed.

5. Set upper cross-member (#1) on the frame with the engine plate mounting tabs facing rearward. Mark and notch the upper frame rail for upper cross-member tabs to slide down over lower cross-member. The tabs on the upper cross-member will locate on the rear side of cross-member brace bracket. **(Figure 14 & 15)**

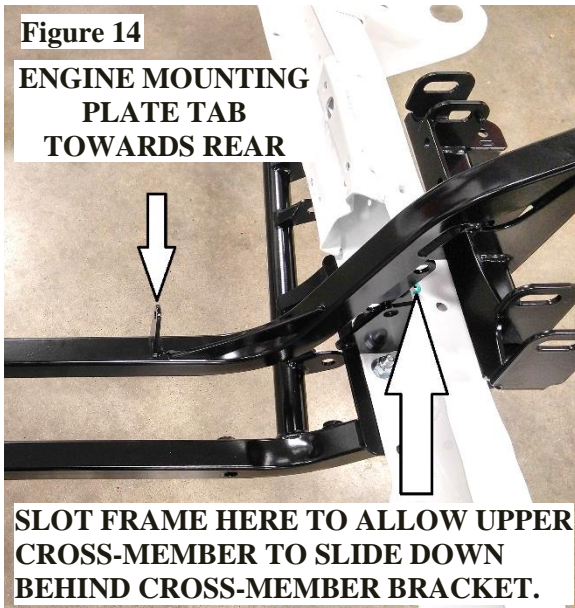

Figure 14

ENGINE MOUNTING PLATE TAB TOWARDS REAR

SLOT FRAME HERE TO ALLOW UPPER CROSS-MEMBER TO SLIDE DOWN BEHIND CROSS-MEMBER BRACKET.

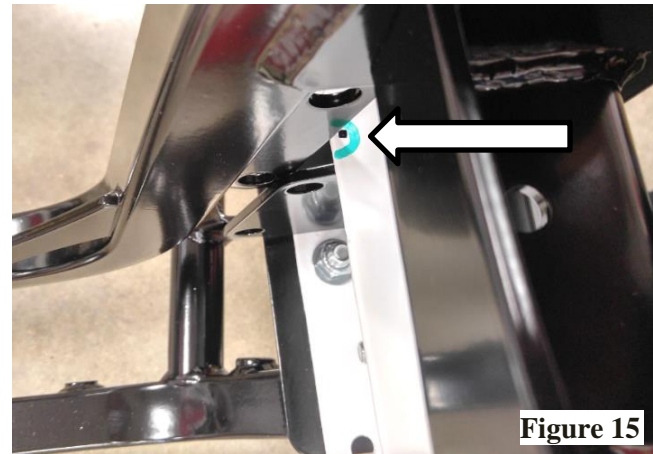

Figure 15



Figure 16

6. Set the upper cross-member in place. Using a pry bar, slide the outside portion of upper cross-member over the lower cross-member. Install remaining 1/2"x1.5" (#28) hardware to connect the upper and lower cross-members. **(Figure 16)**

7. Drill three 3/8" holes and use one existing hole to secure upper cross-member to top frame rail using 3/8"x 1-1/4" hardware (#36) on the outer holes and 3/8"x 1" (#35) on the two inner holes. Evenly tighten all hardware to draw upper cross-member to frame (**Figure 17**)

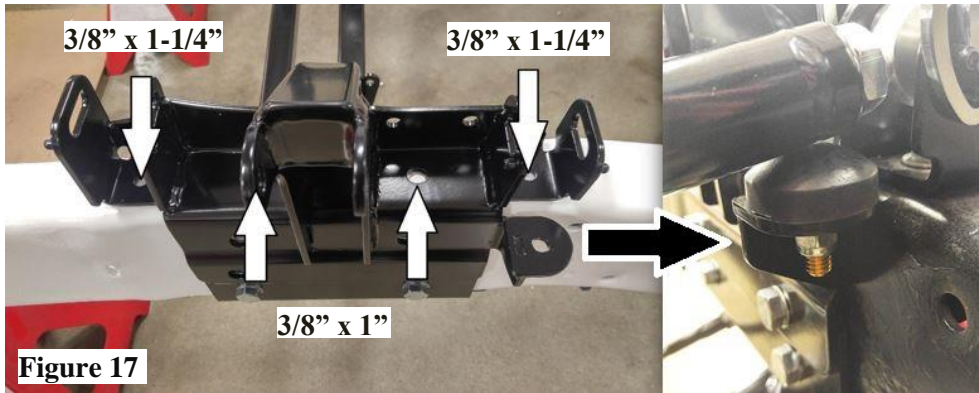

8. Bolt upper cross-member tabs to the inner brace bracket using 1/2"x 1-1/2" mounting hardware (#28)

9. Torque all 1/2" mounting hardware to 75 lb. ft. and all 3/8" hardware to 30 lb. ft.

10. Install droop stop (#12) onto rear of upper cross-member. (**Figure 17**)

11. Install the red anodized lower cross-member brace using 3/8" button head bolts (#37). Torque to 15 lb. ft. (**Figure 18**)

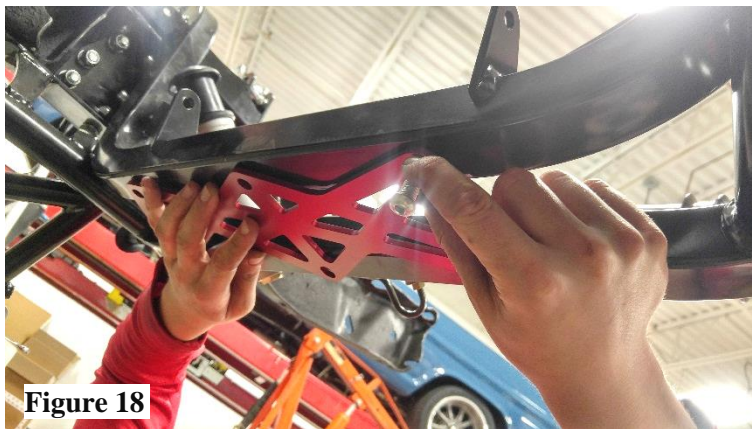

12. Identify the right and left upper control arms using the diagram below, noting that the ball joint is biased towards the front of the truck. (**Figure 19**)

13. Prep the upper control arms for installation by threading the 5/8" jam nuts (#46) onto 5/8" male rod ends (#45). Thread the jam nuts all the way to the base of the rod end. Thread rod ends into upper control arms until 2-3 threads are seen between jam nut and control arm assembly. Leave jam nuts loose until arms are installed to allow alignment with mounting bolts. The rod ends can be adjusted during alignment for caster/camber adjustment.

(**Figure 20 & 21**)

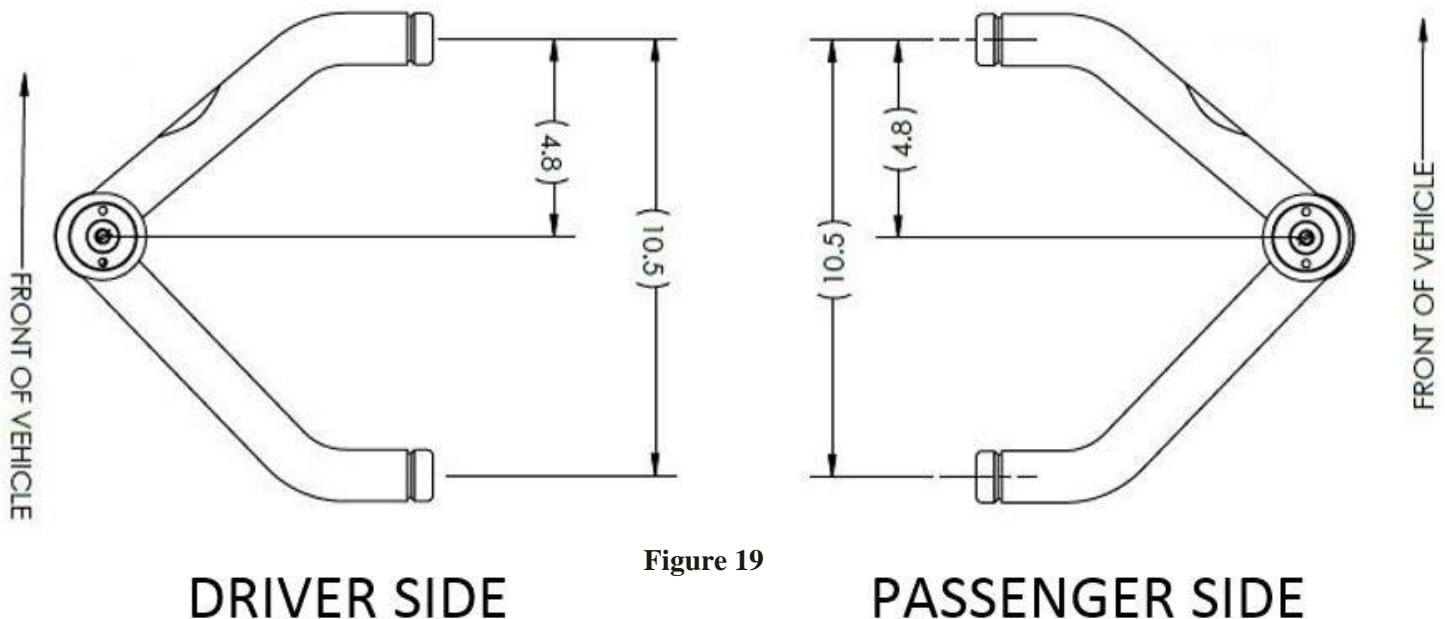

Figure 19

Figure 20

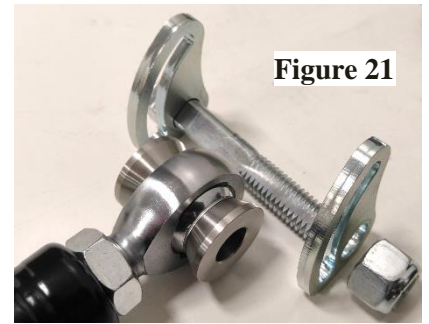
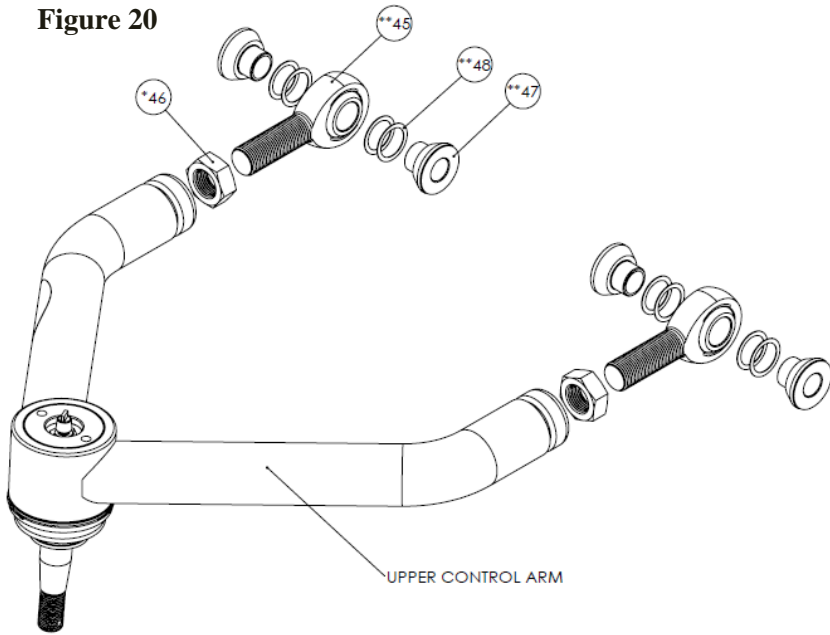

Figure 21

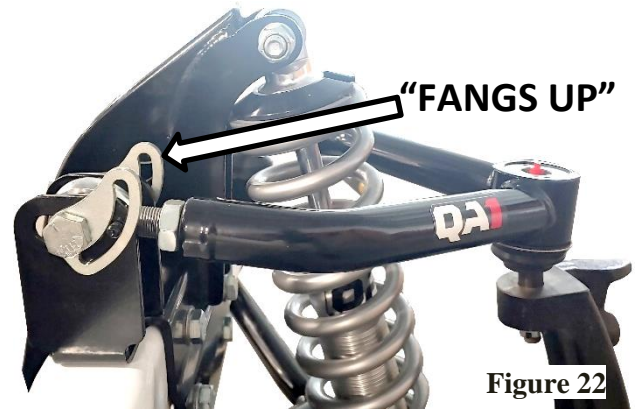

Figure 22

14. Install stepped spacers (#47) into the bore of each rod end starting with two shims (#48). One spacer and two shims per side. Add/adjust shims for even fit front to rear. **(Figure 20-22)**
15. Using four eccentric spacers (#13) per arm, install upper control arms with 1/2" x 3" cam adjust bolts and nylock nuts. Install the camber eccentrics "Fangs UP". Turn the bolt head to adjust the eccentric near the center of the eccentrics range and tighten the nut to 55 lb. ft. Final camber adjustment should be done by a qualified alignment shop. **(Figure 22)**
16. Identify the correct lower control arm orientation with the ball joint facing up and the arched tube of the control arm towards the rear of the truck. **(Figure 23)**

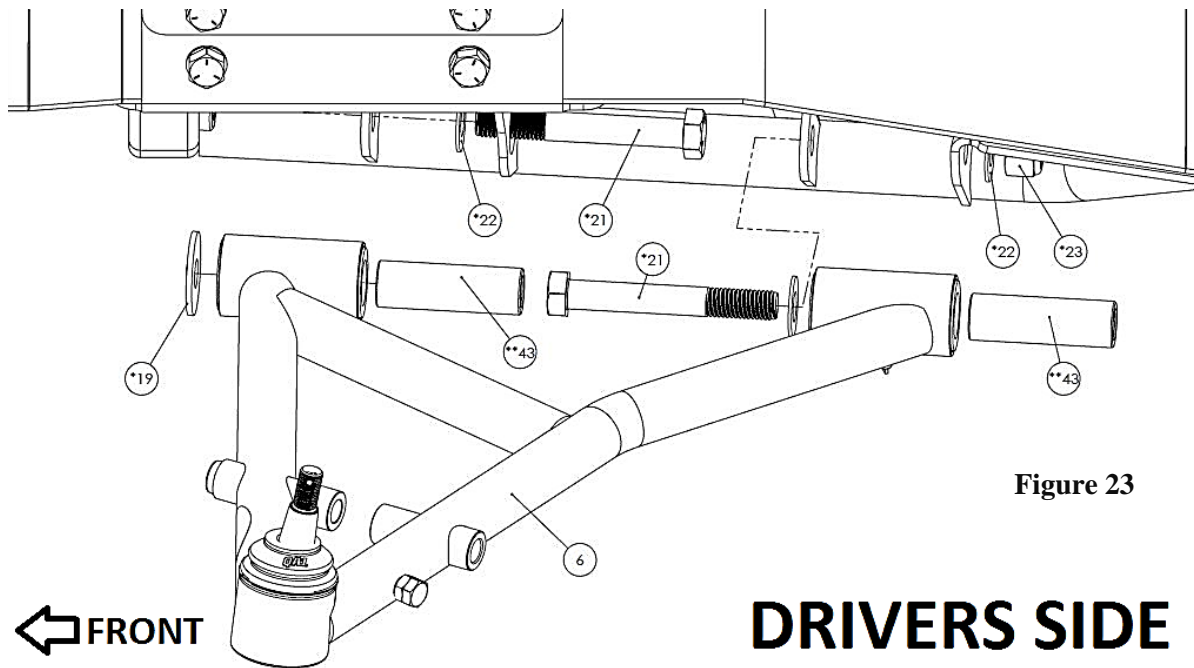

Figure 23

DRIVERS SIDE

17. Install 3.1" length sleeves (#43) into each control arm pivot point.

18. Using 5/8" x 4-1/2" bolts (#21), install the **front connection first**, with one .120" thick washer (#19) between the front of the control arm and the cross-member bracket and a 5/8" SAE washer (#22) under the bolt head. Install the rear connection using the same 5/8" x 4-1/2" bolt (#21), with 5/8" nylock nut (#23), and two 5/8" SAE washers. (#22) Torque bolts to 90 lb. ft.

Refer to the coil-over hardware instructions included with your QA1 shocks to assemble the coil-overs. The included shaft mounted bump stop should be installed onto the shock rod by loosening the eyelet jam nut and removing the shock eyelet. After the eyelet is re-installed, tighten the jam nut to 12 lb. ft.

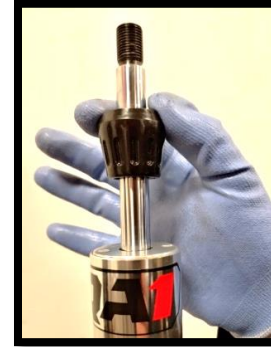

19. Install the coil-overs with the adjustment knob(s) towards the top, facing outward. **(Figure 24)**
20. Install upper connection into the cross-member using two spacers (#18) with the small diameter facing the shock, 1/2" x 2.75" bolt (#27), with two 1/2" washers (#29), and 1/2" nylock nut (#32). Torque to 50 lb. ft.

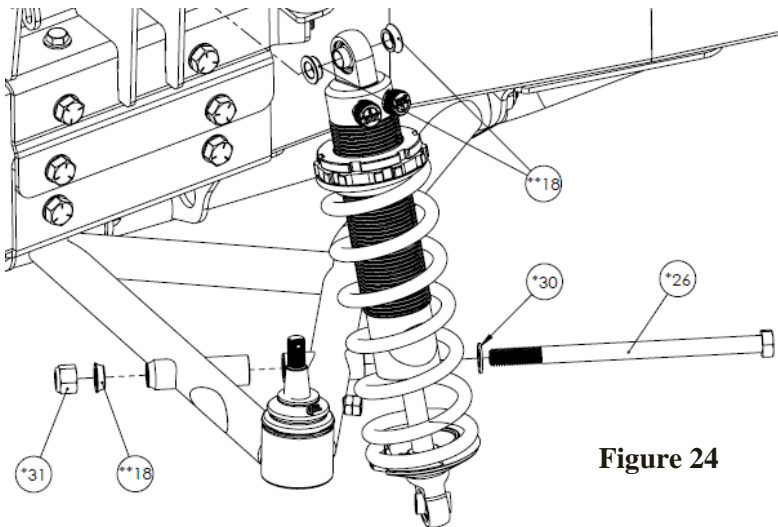

Figure 24

21. Install a 1/2" x 8" bolt (#26) for the lower shock connection inserted from the backside of the control arm with a 1/2" washer (#30) under head. On the front side of the control arm install (#18) spacer (small diameter facing arm) and 1/2" nylock nut (#31) to secure. Torque to 50 lb. ft.

NOTE: If using QA1 front sway bar, the end link connection will be installed on this bolt before installing nylock nut. See instructions included with the front sway bar.

22. Before installing the spindle, adjust the coil-over spring seat collars towards the spring until there is 1.5" of shock thread showing between the locking collar and the base of the shock.
23. The included spindles are similar in design to '79-'81 Camaro. Secure spindle to the upper and lower ball joints using 1/2" SAE washer (#29), castle nuts (#33), and cotter pins. Torque to 60 lb. ft. The upper ball joint uses a 1" extended stud for camber gain. This ball joint will seat with the ball joint boot not in contact with the spindle.



24. The included steering rack is an OE type '79-'93 mustang (Cardone P/N 97-207). Attach steering rack to lower cross-member using 5/8" x 5.5" bolts (#20), one .120" thick washer (#19) under bolt head, with 5/8" SAE washers (#22) and nylock nut (#23). **(Figure 25)**

25. Install user supplied power steering hoses from rack to pump and reservoir. The steering rack pressure port is a 9/16" thread and the return port is 5/8". These ports can be converted to -6 AN with Speedway Motors fitting kit p/n 910-4047. Complete standard bleed procedure of PS system after hose installation.

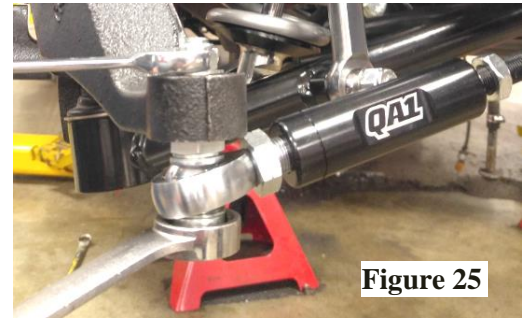

Figure 25

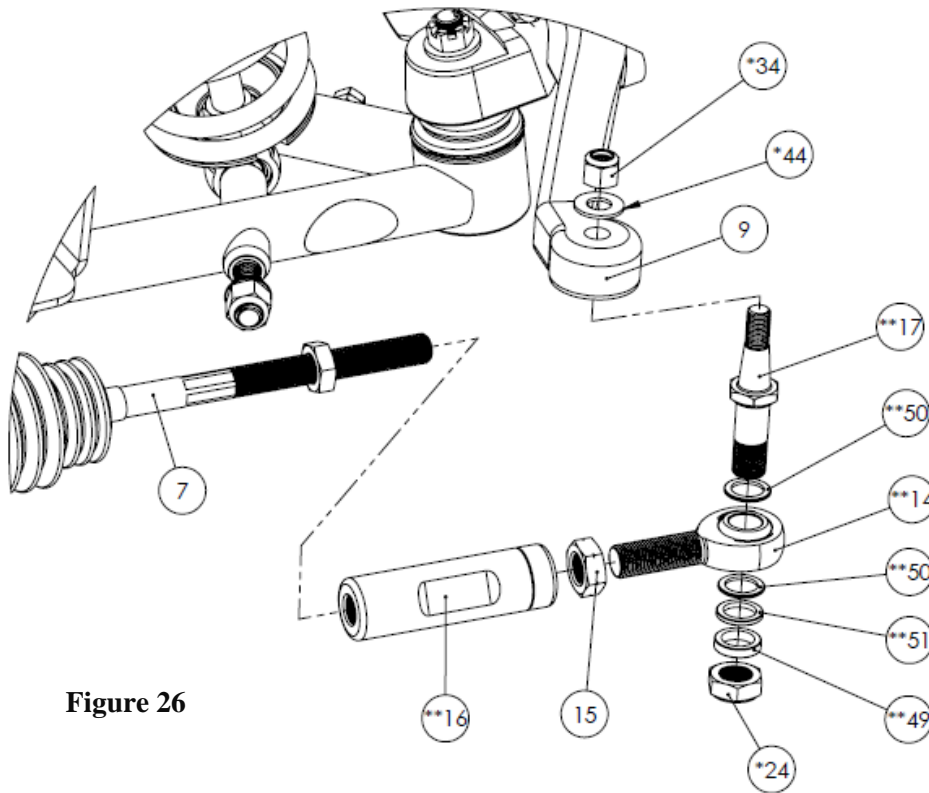

Figure 26

26. Install the left hand threaded 5/8" jam nut (#15) onto left hand threaded 5/8" rod end (#14). Thread the tie rod sleeves onto rod end until threads bottom out. (Figure 26)

27. Install the tie rod sleeves onto the right hand threaded inner tie rod of the steering rack engaging 1-1/2" of thread as a starting point before having truck aligned.

28. This suspension system includes (2) thick, (2) medium, and (4) thin spacers for the tie rod kit. Install (1) thin spacer on top of rod end with the remaining spacers on the bottom of the rod end, followed by the nut. Tighten stud (#17) to spindle to 45 lb. ft. Further bump steer adjustments can be made once final ride height is set. Final tie rod adjustment/Toe should be set by a reputable alignment shop.

29. Install the engine mounting plates that were purchased separately. See the instructions included with the engine mounting kit.

ENGINE	MOUNTING KIT PART #
FE	7740-251
WINDSOR	7740-252
MOD/COYOTE	7740-253
LS	7740-254
429/460 (*see note)	7740-252

*Use Trans Dapt Engine Mount part number 4226

NOTES:

Before installing the engine, refer to the included template and instructions for trimming the inner fender liner.

Coyote swapped trucks can use Ultimate Headers p/n 471111 which was designed specifically for this QA1 suspension.

30. Install the engine and transmission with appropriate transmission cross-member for your application.
31. Install the 79-81 Camaro brake kit of your choosing, including all brake lines and set vehicle ride height.
32. Install user supplied hydraulic connections from pump to new steering rack and follow manufacturers bleed procedure.

Rack and Pinion Steering Connection

With multiple ways and configurations needed to connect the steering rack to the steering column, QA1 suggests the Borgeson ¾-36 x ¾ DD connection (Part # 013449) or similar at the steering rack as a starting point. **(Figure 27)** Using an aftermarket steering column will prevent having to modify the factory steering column. Some engine/header combinations will require up to three steering u-joints.

A professional four wheel alignment is required before driving the vehicle.

Recommended Alignment Specs

Caster	+6.5° ±0.5°
Camber	-0.5° ±0.5°
Toe	+0.05° ±0.05°



READ ALL INSTRUCTIONS CAREFULLY AND THOROUGHLY PRIOR TO STARTING INSTALLATION. PRODUCTS THAT HAVE BEEN INSTALLED ARE NOT ELIGIBLE FOR RETURN. USE THE PROPER JACKING LOCATIONS. DEATH OR SERIOUS INJURY CAN RESULT IF INSTRUCTIONS ARE NOT CORRECTLY FOLLOWED. A GOOD CHASSIS MANUAL, AVAILABLE AT YOUR LOCAL PARTS STORE, MAY ALSO AID IN YOUR INSTALLATION.

• DISCLAIMER / WARRANTY •

QA1 WARRANTS THAT THE PRODUCTS WILL BE FREE FROM DEFECTS IN MATERIAL AND WORKMANSHIP FOR ONE YEAR FROM DATE OF SALE TO THE ORIGINAL PURCHASER. QA1 MAKES NO OTHER WARRANTY OF ANY KIND, EXPRESS OR IMPLIED. QA1 SHALL HAVE NO OBLIGATION UNDER THE FOREGOING WARRANTY WHERE THE DEFECT IS THE RESULT OF IMPROPER OR ABNORMAL USE, YOUR NEGLIGENCE, VEHICLE ACCIDENT, IMPROPER OR INCORRECT INSTALLATION OR MAINTENANCE, NOR WHEN THE PRODUCT HAS BEEN REPAIRED OR ALTERED IN ANY WAY. QA1'S LIABILITY IN THE CASE OF DEFECTIVE PRODUCTS SUBJECT TO THE FOREGOING WARRANTY SHALL BE LIMITED TO THE REPAIR OR REPLACEMENT, AT QA1'S OPTION, OF THE DEFECTIVE PRODUCTS.

THE USER UNDERSTANDS AND RECOGNIZES THAT RACING PARTS, SPECIALIZED STREET ROD EQUIPMENT, AND ALL PARTS AND SERVICES SOLD BY QA1 ARE EXPOSED TO MANY AND VARIED CONDITIONS DUE TO THE MANNER IN WHICH THEY ARE INSTALLED AND USED. QA1 SHALL BEAR NO LIABILITY FOR ANY LOSS, DAMAGE OR INJURY, EITHER TO A PERSON OR TO PROPERTY, RESULTING FROM THE INSTALLATION, DIRECT OR INDIRECT USE OF ANY QA1 PRODUCTS OR INABILITY BY THE BUYER TO DETERMINE PROPER USE OR APPLICATION OF QA1 PRODUCTS. WITH THE EXCEPTION OF THE LIMITED LIABILITY WARRANTY SET FORTH ABOVE, QA1 SHALL NOT BE LIABLE FOR ANY CLAIMS, DEMANDS, INJURIES, DAMAGES, ACTIONS, OR CAUSES OF ACTION WHATSOEVER TO BUYER ARISING OUT OF OR CONNECTED WITH THE USE OF ANY QA1 PRODUCTS. MOTORSPORTS ARE DANGEROUS; AS SUCH, NO WARRANTY OR REPRESENTATION IS MADE AS TO THE PRODUCT'S ABILITY TO PROTECT THE USER FROM INJURY OR DEATH. THE USER ASSUMES THAT RISK!

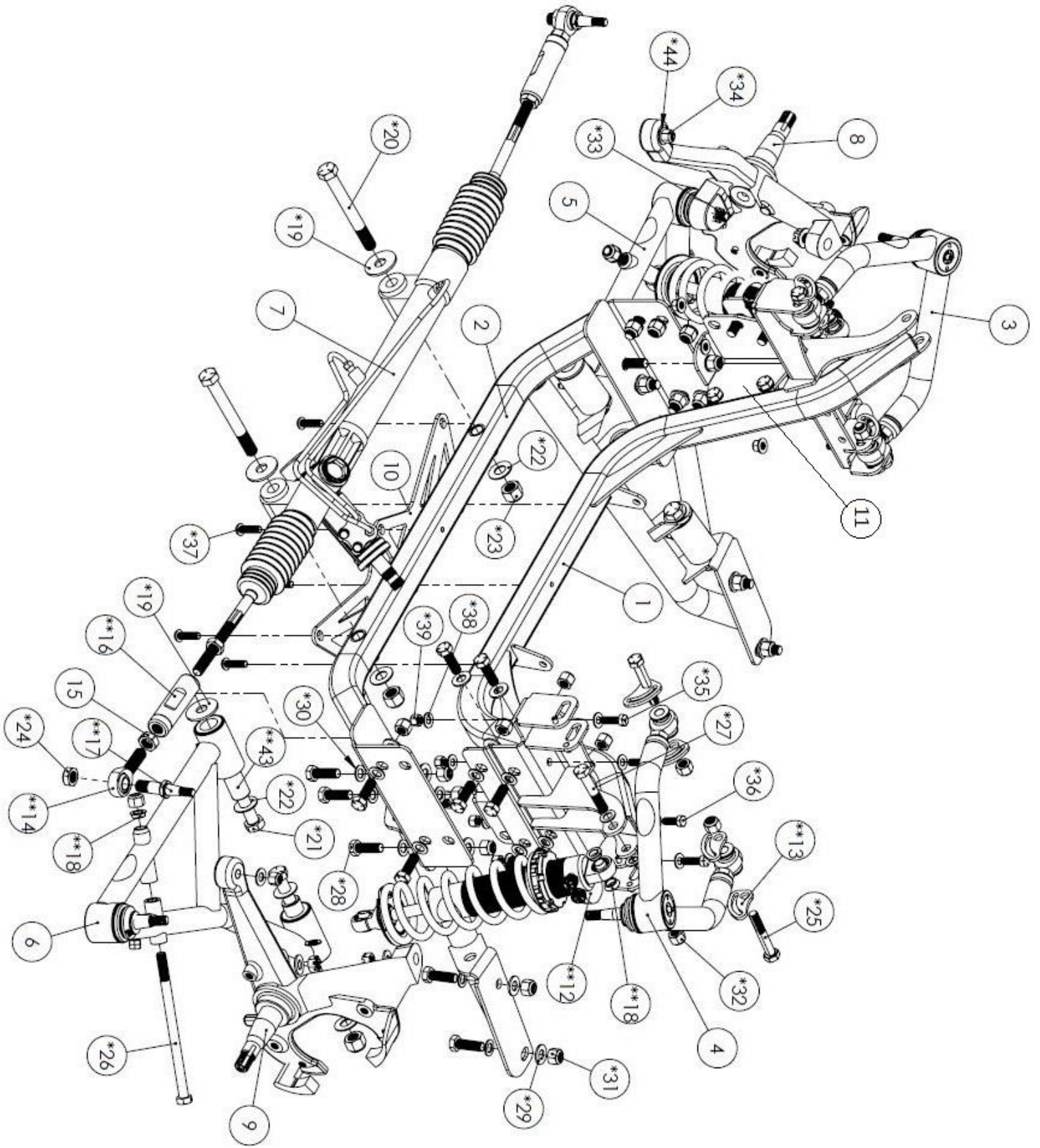

BALLOON #	ITEM#	DESCRIPTION	QTY.
1	7740-239	CROSSMEMBER, FRONT UPPER	1
2	7740-229	CROSSMEMBER, FRONT LOWER	1
3	7720-270	UPPER CONTROL ARM ASM. RH	1
4	7720-271	UPPER CONTROL ARM ASM. LH	1
5	7720-276	LOWER CONTROL ARM ASM., RH	1
6	7720-277	LOWER CONTROL ARM ASM., LH	1
7	9065-101	STEERING GEAR, MUSTANG, POWER	1
8	9056-104	SPINDLE, STOCK STYLE RH	1
9	9056-105	SPINDLE, STOCK STYLE LH	1
10	7740-246	PLATE, X-MEMBER BRACE	1
11	7740-240	BRACKET, X-MEMBER BRACE	2
**12	9047-114	BUMP STOP, FLAT 1.625" OD X .688"	2
**13	9009-105	PLATE, ECCENTRIC ADJUSTER	8
**14	XML10	ROD END (X) ENDURA ALLOY HT	2
15	JNL10S	JAM NUT, STEEL 5/8-18 LH	2
**16	9033-218	BUMPSTEER SLEEVE 9/16-18	2
**17	9029-332	STUD, SPINDLE, BUMPSTER	2
**18	SG84	SPACER, ROD END SS	6
*19	7740-148	WASHER, FLAT .63" ID X 1.80" OD X.12	4
*20	9012-311	BOLT, HEX 5/8-11 X 5.5"	2
*21	9012-114	BOLT, HEX 5/8-11 X 4.5"	4
*22	9005-257	WASHER, FLAT 5/8" SAE	8
*23	9014-131	NUT, NYLOCK 5/8-11	4
*24	9014-323	NUT, NYLOCK JAM 5/8-18	2
*25	7039-225	BOLT, CAM ADJUST 1/2-13 X 3"	4
*26	9012-310	BOLT, HEX 1/2-13 X 8"	2
*27	9012-XXX	BOLT, HEX 1/2-20 X 2.75"	2
*28	9012-XXX	BOLT, HEX 1/2-13 X 1.5"	26
*29	9005-228	WASHER, FLAT 1/2" SAE	20
*30	9005-251	WASHER, FLAT 1/2" AN960-816 CZ	42
*31	9014-279	NUT, NYLOCK 1/2-13	32
*32	9014-107	1/2-20 NYLOCK NUT	2
*33	9014-322	NUT, SLOTTED (CASTLE) 1/2-20	4
*34	9014-442	NUT, NYLOCK 7/16-20	2
*35	9012-179	BOLT, HEX 3/8-16 X 1.25"	4
*36	9012-229	BOLT, HEX 3/8-16 X 1"	4
*37	9012-246	BOLT, BUTTON HEAD 3/8-16 X 1.25"	6
*38	9005-256	WASHER, FLAT 3/8" SAE	18
*39	9014-253	NUT, NYLOCK 3/8-16	8
*40	9014-333	NUT, HEX 3/8-16	2
41	SHOCK ASM.	SHOCK ASSEMBLY	2
42	12HTXXX	SPRING 12" XXXlb/in	2
**43	9033-467	SLEEVE, .63" ID X 1.00" OD X 3.1"	2
*44	9005-243	WASHER, FLAT 7/16" SAE	2
**45	XMR10	ROD END (X) ENDURA ALLOY HT	4
*46	JNR10S	JAM NUT, STEEL 5/8-18 RH	4
**47	9004-177	SPACER, STEPPED, .345" WIDTH	8
**48	9005-293	WASHER, SHIM .656" ID X .843" OD	16