



Technical Support Line: (952) 985-5675 Email: Info@QA1.net

INSTALLATION INSTRUCTIONS

Mustang K-Member Engine Swap Mounts

Part Number	Application
52113	Windsor (fits '79-'95 Mustang)
52114	4.6 (fits 96-04 Mustang)
52115	LS1

TOOLS AND SUPPLIES REQUIRED

- QA1 K Member
- Wrench Set
- Socket Set

PRE-INSTALLATION NOTES

QA1 Engine swap mounts will not work with older QA1 Mustang K-Members with welded on engine mounts.

- 52115 LS engine mounts were designed using '98-'02 F-Body oil pan (Dorman p/n 264-331) and '98-'02 F-body engine mounts. Hedman Conversion Headers (p/n 45850) were used during the design of QA1 K-member swap mounts. Other headers may work. Fitment of other headers should be verified by the end user.
- Now is a great time to consider a QA1 transmission crossmember for your swapped Mustang! Available for many popular GM transmissions.



PART NUMBER	APPLICATION	TRANSMISSION
52108	79-93 Mustang w/LS or SBC	Powerglide, 700R4, TH350, TH200, 4L60E
52109	'79-'93 Mustang w/LS or SBC	T56, TH400, 2004R
52110	'94-'98 Mustang w/LS or SBC	Powerglide, 700R4, TH350, TH200, '95-earlier 4L60E
52111	'94-'98 Mustang w/LS or SBC	'96 or later 4L60E, T56
52112	'94-'98 Mustang w/LS or SBC	TH400, 2004R

ENGINE MOUNT INSTALLATION:

1. Remove engine mounts from the K-Member by removing the (3) mounting bolts on each mount.
2. Install new engine mounts with all hardware (**figure 1**) before Torquing to 24 lb.-ft.

Figure 1

Part #	Description	Qty
1	3/8 NYLON LOCKNUT ZINC	6
2	3/8-16 HEX HEAD GRADE 5 ZINC	6
3	3/8 SAE WASHER ZINC	12

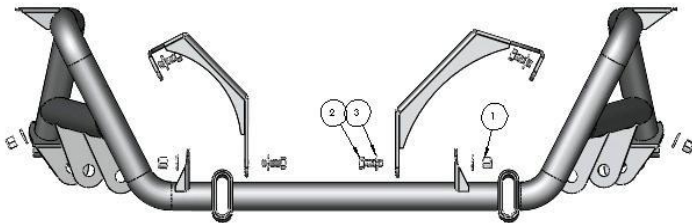
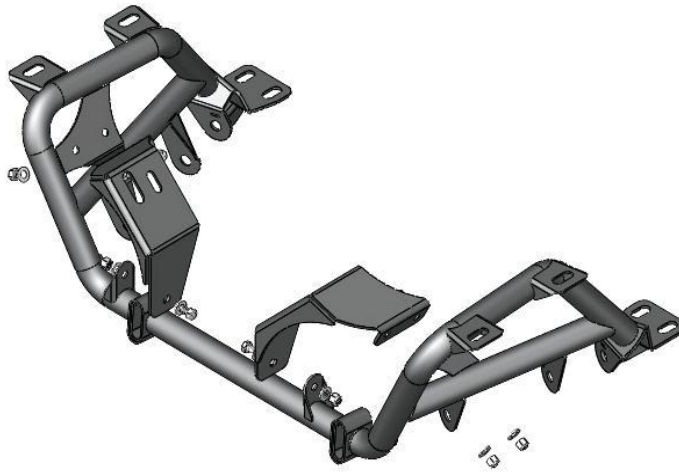

ENGINE MOUNT INSTALLATION DIAGRAM

READ ALL INSTRUCTIONS CAREFULLY AND THOROUGHLY PRIOR TO STARTING INSTALLATION. PRODUCTS THAT HAVE BEEN INSTALLED ARE NOT ELIGIBLE FOR RETURN. USE THE PROPER JACKING LOCATIONS. DEATH OR SERIOUS INJURY CAN RESULT IF INSTRUCTIONS ARE NOT CORRECTLY FOLLOWED. A GOOD CHASSIS MANUAL, AVAILABLE AT YOUR LOCAL PARTS STORE, MAY ALSO AID IN YOUR INSTALLATION.

• **DISCLAIMER / WARRANTY** •

QA1 WARRANTS THAT THE PRODUCTS WILL BE FREE FROM DEFECTS IN MATERIAL AND WORKMANSHIP FOR ONE YEAR FROM DATE OF SALE TO THE ORIGINAL PURCHASER. QA1 MAKES NO OTHER WARRANTY OF ANY KIND, EXPRESSED OR IMPLIED. QA1 SHALL HAVE NO OBLIGATION UNDER THE FOREGOING WARRANTY WHERE THE DEFECT IS THE RESULT OF IMPROPER OR ABNORMAL USE, YOUR NEGLIGENCE, VEHICLE ACCIDENT, IMPROPER OR INCORRECT INSTALLATION OR MAINTENANCE, NOR WHEN THE PRODUCT HAS BEEN REPAIRED OR ALTERED IN ANY WAY. QA1'S LIABILITY IN THE CASE OF DEFECTIVE PRODUCTS SUBJECT TO THE FOREGOING WARRANTY SHALL BE LIMITED TO THE REPAIR OR REPLACEMENT, AT QA1'S OPTION, OF THE DEFECTIVE PRODUCTS.

THE USER UNDERSTANDS AND RECOGNIZES THAT RACING PARTS, SPECIALIZED STREET ROD EQUIPMENT, AND ALL PARTS AND SERVICES SOLD BY QA1 ARE EXPOSED TO MANY AND VARIED CONDITIONS DUE TO THE MANNER IN WHICH THEY ARE INSTALLED AND USED. QA1 SHALL BEAR NO LIABILITY FOR ANY LOSS, DAMAGE OR INJURY, EITHER TO A PERSON OR TO PROPERTY, RESULTING FROM THE INSTALLATION, DIRECT OR INDIRECT USE OF ANY QA1 PRODUCTS OR INABILITY BY THE BUYER TO DETERMINE PROPER USE OR APPLICATION OF QA1 PRODUCTS. WITH THE EXCEPTION OF THE LIMITED LIABILITY WARRANTY SET FORTH ABOVE, QA1 SHALL NOT BE LIABLE FOR ANY CLAIMS, DEMANDS, INJURIES, DAMAGES, ACTIONS, OR CAUSES OF ACTION WHATSOEVER TO BUYER ARISING OUT OF OR CONNECTED WITH THE USE OF ANY QA1 PRODUCTS. MOTORSPORTS ARE DANGEROUS; AS SUCH, NO WARRANTY OR REPRESENTATION IS MADE AS TO THE PRODUCT'S ABILITY TO PROTECT THE USER FROM INJURY OR DEATH. THE USER ASSUMES THAT RISK!

Dedicated Technical Support Team

QA1 is dedicated to providing quality support and instructions. We employ passionate racers and car enthusiasts that know our products and the industry to better serve you.

Check out our tech videos at www.YouTube.com/QA1Tech for:

- Frequently Asked Questions
- Quick Tips
- Install Information
- Tuning and Repair Guides
- Other technical information

Or call to speak with one of our experts: 1.800.721.7761

*Our technical support and order lines are open Monday - Friday, 8 am to 5 pm CST.



Facebook.com/QA1Motorsports



Twitter.com/QA1Motorsports



Instagram.com/QA1Motorsports



www.QA1.net/Tech