



Technical Support Line: (952) 985-5675 Email: Info@QA1.net

INSTALLATION INSTRUCTIONS

QA1 P/N 52601 & 52602 Control Arms

'63-'86 Chevrolet C10/ GMC C15, C1500, '87-'91 Chevrolet/GMC R10

READ ALL INSTRUCTIONS CAREFULLY AND THOROUGHLY PRIOR TO STARTING INSTALLATION. PRODUCTS THAT HAVE BEEN INSTALLED ARE NOT ELIGIBLE FOR RETURN. USE THE PROPER JACKING LOCATIONS. DEATH OR SERIOUS INJURY CAN RESULT IF INSTRUCTIONS ARE NOT CORRECTLY FOLLOWED. A GOOD CHASSIS MANUAL, AVAILABLE AT YOUR LOCAL PARTS STORE, MAY ALSO AID IN YOUR INSTALLATION.

• DISCLAIMER / WARRANTY •

QA1 WARRANTS THAT THE PRODUCTS WILL BE FREE FROM DEFECTS IN MATERIAL AND WORKMANSHIP FOR ONE YEAR FROM DATE OF SALE TO THE ORIGINAL PURCHASER. QA1 MAKES NO OTHER WARRANTY OF ANY KIND, EXPRESS OR IMPLIED. QA1 SHALL HAVE NO OBLIGATION UNDER THE FOREGOING WARRANTY WHERE THE DEFECT IS THE RESULT OF IMPROPER OR ABNORMAL USE, YOUR NEGLIGENCE, VEHICLE ACCIDENT, IMPROPER OR INCORRECT INSTALLATION OR MAINTENANCE, NOR WHEN THE PRODUCT HAS BEEN REPAIRED OR ALTERED IN ANY WAY. QA1'S LIABILITY IN THE CASE OF DEFECTIVE PRODUCTS SUBJECT TO THE FOREGOING WARRANTY SHALL BE LIMITED TO THE REPAIR OR REPLACEMENT, AT QA1'S OPTION, OF THE DEFECTIVE PRODUCTS.

THE USER UNDERSTANDS AND RECOGNIZES THAT RACING PARTS, SPECIALIZED STREET ROD EQUIPMENT, AND ALL PARTS AND SERVICES SOLD BY QA1 ARE EXPOSED TO MANY AND VARIED CONDITIONS DUE TO THE MANNER IN WHICH THEY ARE INSTALLED AND USED. QA1 SHALL BEAR NO LIABILITY FOR ANY LOSS, DAMAGE OR INJURY, EITHER TO A PERSON OR TO PROPERTY, RESULTING FROM THE INSTALLATION, DIRECT OR INDIRECT USE OF ANY QA1 PRODUCTS OR INABILITY BY THE BUYER TO DETERMINE PROPER USE OR APPLICATION OF QA1 PRODUCTS. WITH THE EXCEPTION OF THE LIMITED LIABILITY WARRANTY SET FORTH ABOVE, QA1 SHALL NOT BE LIABLE FOR ANY CLAIMS, DEMANDS, INJURIES, DAMAGES, ACTIONS, OR CAUSES OF ACTION WHATSOEVER TO BUYER ARISING OUT OF OR CONNECTED WITH THE USE OF ANY QA1 PRODUCTS. MOTORSPORTS ARE DANGEROUS; AS SUCH, NO WARRANTY OR REPRESENTATION IS MADE AS TO THE PRODUCT'S ABILITY TO PROTECT THE USER FROM INJURY OR DEATH. THE USER ASSUMES THAT RISK!

TOOLS AND SUPPLIES REQUIRED

- Floor Jack
- Drill & Drill Bit Set
- SAE Wrench Set
- Ratchet & SAE Socket Set
- Jack Stands
- Torque Wrench
- 1891-106 Ball Joint Tool Kit

Pre-Installation Notes

QA1 C10 control arms are designed to use '73-'87 spindles. QA1 upper and lower control arms will work in conjunction with OE control arms with the correct ball joints, but the caster increase will only be about four degrees.

'71-'72 trucks can use '73 outer tie rod ends (Moog P/N ES409RT or equivalent) with the later spindles.

'63-'70 trucks will need to update the steering system to the '73 - later style or use QA1 adaptor tie rod sleeves, P/N 5256.

P/N 52601 lower control arms are designed to use QA1 front sway bar P/N 52896 and will not work with OE sway bars.

Disassembly Instructions

1. Raise support the vehicle by the frame rails with jack stands on a stable surface.
2. Remove the front wheels and brake calipers. For '73 and newer trucks, the brake hoses will need to be unbolted from the upper control arms. **Caution:** Do not allow the brake caliper to hang by the brake hose as this can damage the brake hose.

3. Unbolt the sway bar from the lower control arms if equipped with a sway bar.
4. Disconnect the lower shock mount from the lower control arm.
5. Remove the cotter pins from the ball joints and loosen the castle nuts. Do not remove the castle nuts at this time. Only loosen the castle nut on the control arm being replaced if both the upper and lower control arms are not being replaced.
6. Strike the flat surface on the spindle near the ball joint with a hammer to separate the ball joints from the spindle. A ball joint separating tool (pickle fork) may be required. See **Figure 1**.
7. Using a spring compressor, compress the front springs to take pressure off the lower control arm.
8. Place a floor jack under the lower control arm and remove the ball joint castle nuts. Lower the control arm out of the way. The spindle and spring can now be removed from the vehicle.
9. Remove the U-bolts retaining the lower control arm to the cross member and remove the lower control arms from the vehicle.
10. For '73-'91 models, the brake hose must be removed from the upper control arm before the control arm can be removed from the vehicle. The hose will need to be relocated to the cross member during reassembly if QA1 upper control arms are used.
11. Remove the nuts from the upper control arm cross shaft and remove the upper control arm and shims from the vehicle.



Figure 1

Installation Instructions

1. Identify the left and right control arms using **Figure 2**.
2. Install the QA1 upper control arm with the flat side of the cross shaft towards the mount. **Note:** The factory concave spacers will be reused for '63-'72 trucks. See **Figure 3**. Torque the nuts to 70 lb. ft.

Figure 2

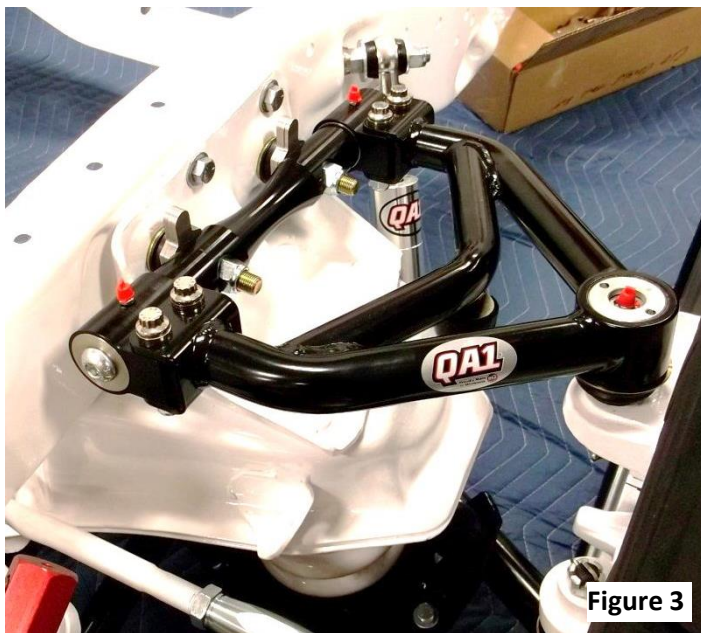
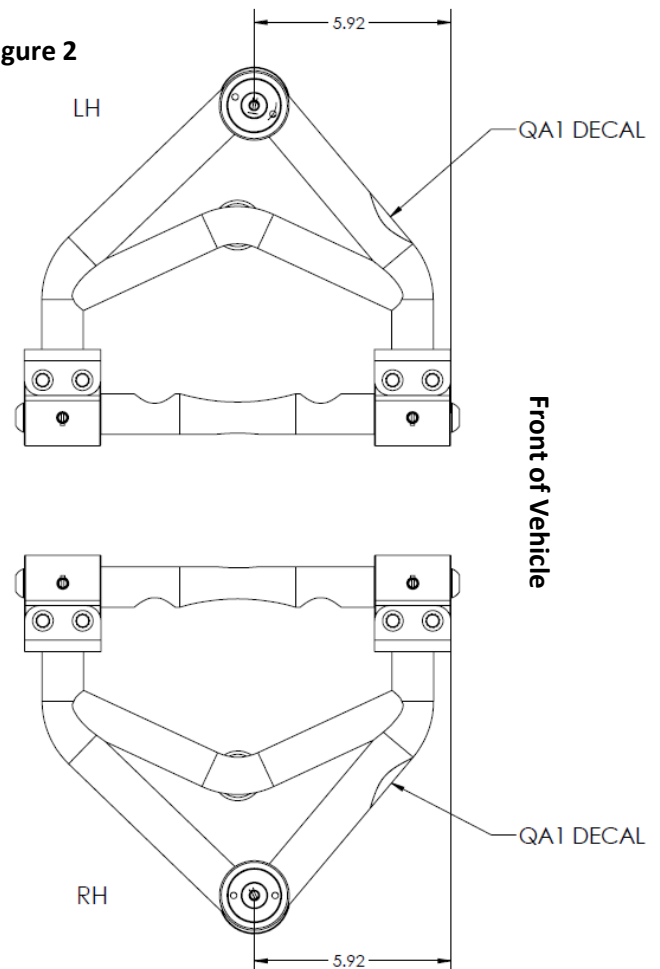

Figure 3

3. The lower control arm U-bolt holes on the cross member will need to be enlarged to 9/16" for '72 and earlier trucks to accept the supplied 9/16" U-bolts.
4. Inspect the lower control arm mounts on the cross member for burrs or sharp edges that could dig into the cross shaft and clean up as necessary. See **Figure 4**.
5. Install the bump stop mount and bump stop on the lower control arm with the supplied 3/8" hardware as shown in **Figure 7** on page 4. These brackets are right and left had specific and should be installed with the steering stop towards the rear of the arm.
6. Install the QA1 lower control arm with the supplied U-bolts. The alignment dowel on the cross member must be seated into the cross shaft. Torque the U-bolt nuts evenly to 70 lb. ft.
7. Reinstall the spindle on the upper ball joint.
8. Reinstall the coil spring making sure to rotate the spring in the upper spring pocket so it is indexed into the recess and raise the lower control arm up to spindle and reconnect the ball joint. The spring isolator on the lower control arm should be rotated to match up with the end of the spring at this time.
9. Tighten the upper ball joint castle nuts to 50 lb. ft. and the lower ball joint castle nut to 90 lb. ft. Once torqued, tighten the nuts until the cotter pin is able to be installed.
10. When using QA1 upper control arms, 1973 and later trucks will need the brake hose rerouted to the front side of the spring pocket on the cross member and attached there using the factory bolt and nut as shown in **Figure 5 & 6**.

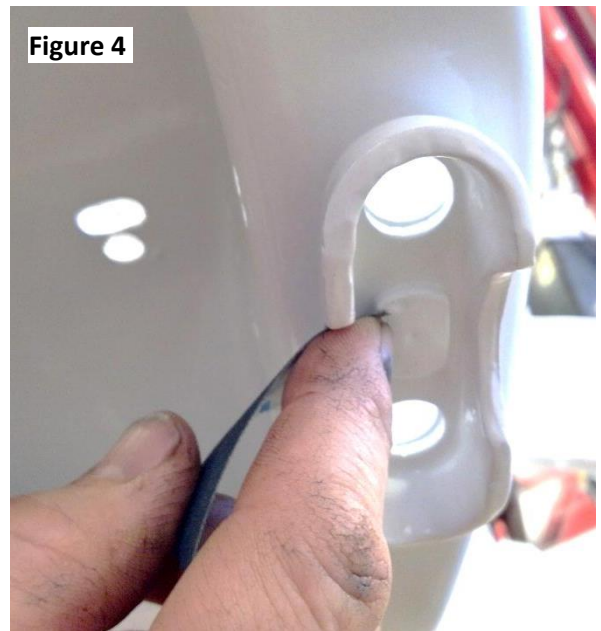

Figure 4

- a. Drill a 3/8" hole just above the flange on the cross member.
- b. Insert the locating tab for the brake hose mount and mark the location for the bolt.
- c. Drill a 5/16" hole and mount the brake hose using the OE mounting bolt and nut.
- d. To help ensure the steering does not contact the brake hose, rotate the clamps and bolts for the tie rod adjusters towards the front of the truck. Bend the mounting bracket to reposition the hose as needed.



Figure 5

11. If the truck has QA1 shocks, remove the sleeve from the lower shock eyelet by removing the snap rings on the sleeve and pressing it out of the bushing. **Note:** If using a brand of shock other than QA1, it will need to have a 5/8" ID for the lower shock mount.
12. Install sleeve p/n 9033-104 into the bushing and attach the shock to the lower control arm with a washer on each side of the bushing and 1/2" Nylock nut, p/n 9014-479.
13. QA1 Sway bar P/N 52896 can now be installed. Refer to the instructions included with the sway bar for this step.
14. Reinstall the brake calipers and wheels.
15. Pump the brake pedal to seat the brake pads against the rotor. Bleed the brakes before driving if the brake hydraulic system has been opened.



Figure 6

Caution: QA1 does not recommend driving the vehicle until it has been properly aligned due to major changes in suspension geometry that will affect the handling characteristics of the vehicle. A front end alignment should be performed by a qualified alignment shop after any changes to the suspension system.

Alignment Information

These components are designed to add more caster and negative camber. It is a good idea to make the alignment shop aware of this, as the alignment shop will only try to align the vehicle to factory specs. These alignment specifications are for vehicles equipped with both QA1 upper and lower control arms. Vehicles with other configurations may not be able to achieve these alignment specifications.

Camber: -0.5° ± 0.5°
 Caster: +8.0° ± 0.5°
 Toe: +0.2° ± 0.1°

Maintenance of QA1 Ultimate Ball Joints

Grease using high quality NLGI #2 GC-LB Lithium based grease and check preload on a regular basis. Check and set ball joint preload at least annually or every 3,000 miles, whichever comes first. NOTE: Preload on the ball stud can be set with the ball joint attached to the control arm if the spring is unloaded

1. Using the QA1 spanner socket from Ball Joint Tool Kit (p/n 1891-106) loosen the lock nut by turning counter clockwise.
2. Using the QA1 hex key, torque the torque nut to 25-30 in. lbs. and then back off 90°.
3. Using the QA1 hex key, a 1/2" open-ended wrench or socket, and the QA1 spanner wrench, tighten the lock nut while holding the torque nut, locking them together to 25 ft. lbs.
4. Re-check the lash on the ball stud and adjust as needed. The ball stud should not have any axial lash.

ITEM #	PART #	DESCRIPTION	QTY
1	52601 LH & RH	LOWER CONTROL ARM	2
2	9037-613 RH 9037-614 LH	BRACKET, STEERING STOP, OE	2
3	*	BOLT, HEX 3/8-16 X 1"	4
4	*	WASHER, FLAT 3/8" SAE	10
5	*	NUT, NYLOCK 3/8-16	4
6	*9047-113	BUMP STOP, BULLET 1.5" OD X 1.56" TALL	2
7	*	NUT, HEX 3/8-16	2
8	*	WASHER, FLAT 5/8" SAE	4
9	*9033-104	SLEEVE, .625" ID X .75" OD X 1.25	2
10	*	WASHER, FLAT 7/16" USS	2
11	*	1/2-20 NYLOCK NUT	2
12	*	NUT, SLOTTED (CASTLE) 5/8-18	2
13	*	COTTER PIN 7/64" X 1.25"	2

* INCLUDED IN HARDWARE KIT 7039-219

RH (PASSENGER) SIDE COMPONENTS SHOWN

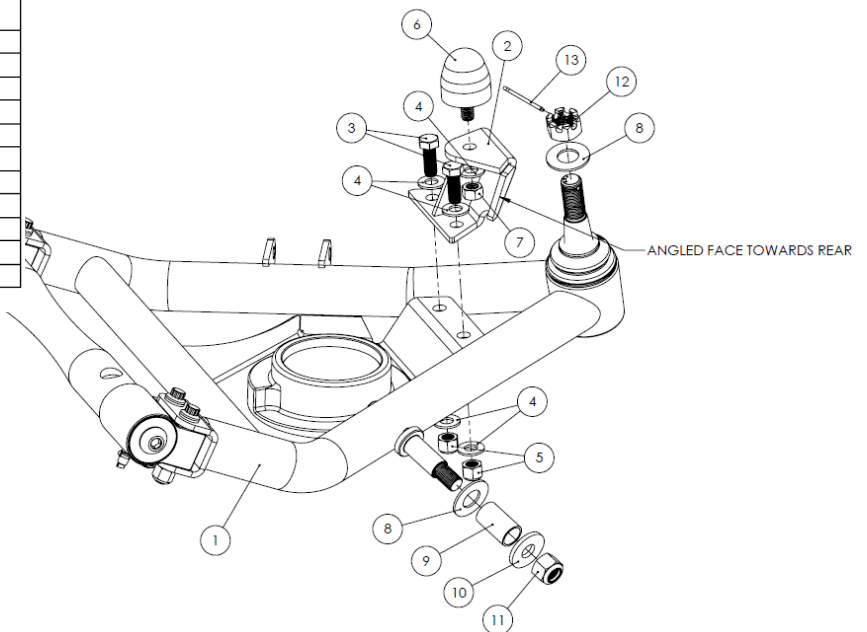

Figure 4

Dedicated Technical Support Team

QA1 is dedicated to providing quality support and instructions. We employ passionate racers and car enthusiasts that know our products and the industry to better serve you.

Check out our tech videos at www.YouTube.com/QA1Tech for:

- Frequently Asked Questions
- Quick Tips
- Install Information
- Tuning and Repair Guides
- Other technical information

Or call to speak with one of our experts: 1.800.721.7761

*Our technical support and order lines are open Monday - Friday, 8 am to 5 pm CST.



Facebook.com/QA1Motorsports



Twitter.com/QA1Motorsports



Instagram.com/QA1Motorsports



www.QA1.net/Tech