



DON'T FORGET
These instructions can be found in
color and expandable at QA1.net

Technical Support Line: (952) 985-5675 Email: sales@QA1.net

INSTALL INSTRUCTIONS

*QA1 P/N MU1RCA, MU2RCA, MU3RCA, MU1ESA, MU2ESA, MU3ESA
'79-'04 MUSTANG RACE SERIES CONTROL ARMS*

READ ALL INSTRUCTIONS CAREFULLY AND THOROUGHLY PRIOR TO STARTING INSTALLATION. PRODUCTS THAT HAVE BEEN INSTALLED ARE NOT ELIGIBLE FOR RETURN. USE THE PROPER JACKING LOCATIONS. DEATH OR SERIOUS INJURY CAN RESULT IF INSTRUCTIONS ARE NOT CORRECTLY FOLLOWED. A GOOD CHASSIS MANUAL, AVAILABLE AT YOUR LOCAL PARTS STORE, MAY ALSO AID IN YOUR INSTALLATION.

• DISCLAIMER / WARRANTY •

QA1 WARRANTS THAT THE PRODUCTS WILL BE FREE FROM DEFECTS IN MATERIAL AND WORKMANSHIP FOR ONE YEAR FROM DATE OF SALE TO THE ORIGINAL PURCHASER. QA1 MAKES NO OTHER WARRANTY OF ANY KIND, EXPRESS OR IMPLIED. QA1 SHALL HAVE NO OBLIGATION UNDER THE FOREGOING WARRANTY WHERE THE DEFECT IS THE RESULT OF IMPROPER OR ABNORMAL USE, YOUR NEGLIGENCE, VEHICLE ACCIDENT, IMPROPER OR INCORRECT INSTALLATION OR MAINTENANCE, NOR WHEN THE PRODUCT HAS BEEN REPAIRED OR ALTERED IN ANY WAY. QA1'S LIABILITY IN THE CASE OF DEFECTIVE PRODUCTS SUBJECT TO THE FOREGOING WARRANTY SHALL BE LIMITED TO THE REPAIR OR REPLACEMENT, AT QA1'S OPTION, OF THE DEFECTIVE PRODUCTS.

THE USER UNDERSTANDS AND RECOGNIZES THAT RACING PARTS, SPECIALIZED STREET ROD EQUIPMENT, AND ALL PARTS AND SERVICES SOLD BY QA1 ARE EXPOSED TO MANY AND VARIED CONDITIONS DUE TO THE MANNER IN WHICH THEY ARE INSTALLED AND USED. QA1 SHALL BEAR NO LIABILITY FOR ANY LOSS, DAMAGE OR INJURY, EITHER TO A PERSON OR TO PROPERTY, RESULTING FROM THE INSTALLATION, DIRECT OR INDIRECT USE OF ANY QA1 PRODUCTS OR INABILITY BY THE BUYER TO DETERMINE PROPER USE OR APPLICATION OF QA1 PRODUCTS. WITH THE EXCEPTION OF THE LIMITED LIABILITY WARRANTY SET FORTH ABOVE, QA1 SHALL NOT BE LIABLE FOR ANY CLAIMS, DEMANDS, INJURIES, DAMAGES, ACTIONS, OR CAUSES OF ACTION WHATSOEVER TO BUYER ARISING OUT OF OR CONNECTED WITH THE USE OF ANY QA1 PRODUCTS. MOTORSPORTS ARE DANGEROUS; AS SUCH, NO WARRANTY OR REPRESENTATION IS MADE AS TO THE PRODUCT'S ABILITY TO PROTECT THE USER FROM INJURY OR DEATH. THE USER ASSUMES THAT RISK.

TOOLS AND SUPPLIES REQUIRED

- Floor Jack
- Jack Stands
- Tire Chocks
- Coil-over Struts
- Tape Measure
- Anti-seize
- Torque Wrench
- Common Hand Tools

REMOVAL:

1. Before starting the installation of your QA1 Race Series control arms read the instructions carefully and thoroughly. A good service manual, available at your local parts store may aid in the installation. Check to make all of the parts and tools needed to complete this installation are on hand.
2. Jack up the car so that jack stands can be placed under the frame. Let the jack down so that the frame sets securely on the stands.
3. Remove the wheels and then unbolt the brake calipers. Secure the brake calipers out of the way of the control arms (*do not let the caliper hang from the brake line. This can cause damage to the brake line*). For vehicles equipped with ABS, refer to your Ford manual for safe removal.
4. Remove the sway bar end links from the vehicle. (Inspect for bushing wear and replace as needed)
5. Use the floor jack to support one of the A-arm assemblies. Jack the A-arm up just enough to take the load off of the strut and spindle. Use of a spring compressor to contain the spring energy is highly recommended. (Fox body cars will require the removal of the rotor backing plate before continuing.) Remove the cotter pin from the castle nut on the ball joint. Loosen the castle nut enough to separate the ball joint. Once the ball joint has been loosened from the spindle the castle nut should be removed. Slowly, CAREFULLY, let the A-arm assembly down until the spring is free and can be removed.
6. Repeat this procedure for the other side.
7. Loosen and remove the two bolts and nuts holding each A-arm into the K-member.

8. Inspect the bolts for any defects or wear. Replace if needed.

Balloon Number	Description	Qty
1	SPACER, 1"OD X .625" ID X .5" ALUMINUM	4
2	SPACER, 1"OD X .625" ID X 1.5" ALUMINUM	1
3	WASHER, FLAT 5/8"	2
4	SPACER, 1" OD X .625" ID X 1.38" ALUMINUM	1
5	NUT, NYLOCK 5/8-11	2

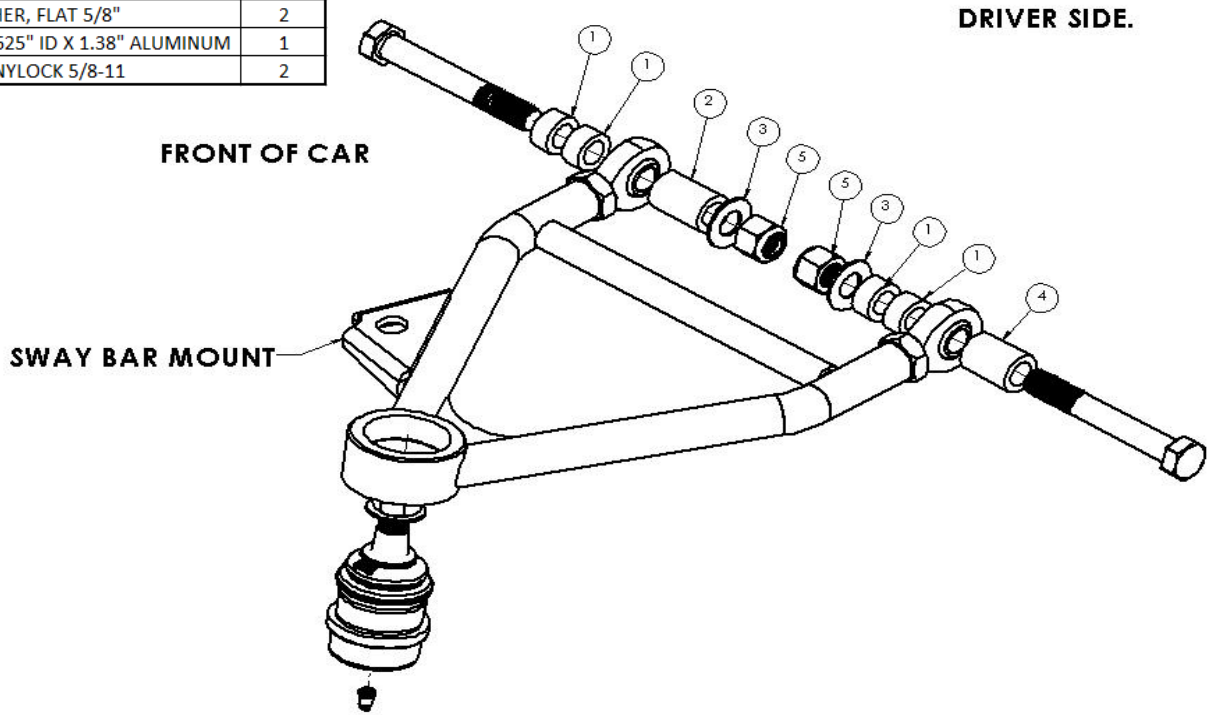

NOTE: Installation of control arms to QA1 K member will slightly vary as the front bolt will thread into the K member.

PRE-INSTALLATION INSTRUCTIONS:

1. Identify the left and right side A-arms. The tube with the sway bar attachment will point to the front of the car.
2. Lightly coat the threads of the included rod ends with Permatex Anti-seize to prevent thread damage.
3. Install 3/4"-16 jam nuts onto 3/4"-16 threaded rod ends and install into control arm.
4. Place control arm pivot points against a flat surface and measure to the center of the ball joint to the following length.



CONTROL ARM PART NUMBER	END OF ROD END TO CENTER OF BALL JOINT
MU1RCA	13.687"
MU2RCA	14.875"
MU3RCA	14.687"

INSTALLATION INSTRUCTIONS:

1. Install the control arm into the K-member on each side of the car using the included spacers. Identify the different sized spacers and install as shown in **Figure 1**. *Note: The age and condition of your stock K-member may require resizing of QA1 Race Series control arm spacers for correct fitment.*
2. Tighten control arm hardware. Keep in mind final 90 lb.-ft. torque should be done with car at ride height as to not bind the bushings.

- Grease both ball joints using general automotive grease or synthetic grease.

NOTE: IF THE VEHICLE WAS NOT PREVIOUSLY USING COIL-OVER STRUTS, REFER TO THE NEW COIL-OVER INSTRUCTIONS BEFORE CONTINUING.

- Reinstall the brake rotor, caliper, and backing plates.
- Reinstall the ABS sensor.
- Reinstall both front wheels.
- Set ride height by adjusting the spring seat adjuster on the body of the strut.
- Lock the spring seat adjuster once desired ride height is achieved.
- Double check all bolts and make sure that they are torqued to manufacture specifications.
- Torque control arms to 90 lb.-ft. with car at ride height.
- Bring the vehicle to a reputable shop for a quality frontend alignment to factory specs.

Maintenance of QA1 Ultimate Ball Joints

Grease using high quality lithium grease and check preload on a regular basis. Check and set ball joint preload at least annually or every 3,000 miles, whichever comes first. NOTE: Preload on the ball stud can be set with the ball joint attached to the control arm if the spring is unloaded and the ball joint taper is free from the spindle. Preload can also be set prior to installing the ball joint.

- Using the QA1 spanner socket from Ball Joint Tool Kit (p/n 1891-106) loosen the lock nut by turning counter clockwise.
- Using the QA1 hex key, torque the torque nut to 25-30 in. lbs. and then back off 90°.
- Using the QA1 hex key, a ½" open-ended wrench or socket, and the QA1 spanner wrench, tighten the lock nut while holding the torque nut, locking them together to 25 ft. lbs.
- Re-check the lash on the ball stud and adjust as needed. The ball stud should not have any axial lash.
- Using a grease gun, lubricate and rotate the ball stud by hand until the grease is visible on the bottom of the ball. If the ball joint is on the car, move the suspension up and down to get the same effect. Note: Excessive grease may result in hydraulic lock. If this occurs, move the ball stud until pressure is relieved and the ball stud freely rotates.

Dedicated Technical Support Team

QA1 is dedicated to providing quality support and instructions. We employ passionate racers and car enthusiasts that know our products and the industry to better serve you.

Check out our tech videos at www.YouTube.com/QA1Tech for:

- Frequently Asked Questions
- Quick Tips
- Install Information
- Tuning and Repair Guides
- Other technical information

Or call to speak with one of our experts: 1.800.721.7761

*Our technical support and order lines are open Monday - Friday, 8 am to 5 pm CST.



Facebook.com/QA1Motorsports



Twitter.com/QA1Motorsports



Instagram.com/QA1Motorsports



www.QA1.net/Tech