



These instructions can be found in color and expandable at QA1.net

Technical Support Line: (952) 985-5675 Email: sales@QA1.net

**INSTALLATION INSTRUCTIONS**

'65-'72 F100 Engine Swap Mounts

P/N 7740-251 thru 7740-254



ENGINE	MOUNTING KIT PART #
FE	7740-251
WINDSOR	7740-252
MOD/COYOTE	7740-253
LS	7740-254
429/460*	7740-252

\*Use with Trans Dapt 4226 conversion mounts

**TOOLS AND SUPPLIES REQUIRED**

- QA1 F100 Front Suspension Conversion
- Wrench Set
- Socket Set

**PRE INSTALLATION NOTES:**

The QA1 F100 front suspension systems move the engine towards the center of the engine bay. The stock engine location is to the passenger side of the truck for clearance around the stock steering box. The engine placement for all engines in this QA1 suspension have been shifted to the driver's side (left) to help with header clearance on the passenger side of the trucks. The transmission tunnel and recess on the firewall are also biased from the factory.

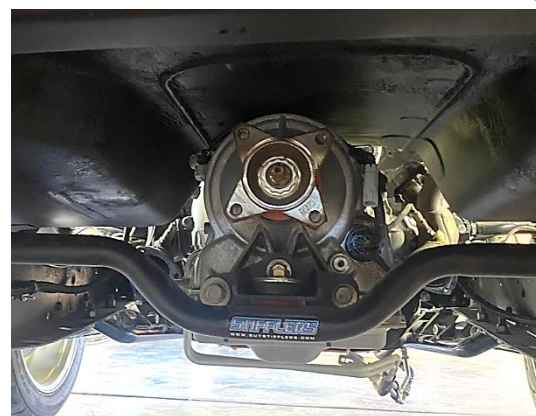

The engine mounts use a total for both Left & Right mounts: (6) 3/8"-16 X 1" bolts, (12) 3/8" SAE Washers, and (6) 3/8"-16 Nylock nuts. This hardware comes in hardware kit 7039-225.

The LS mount kit will come with 12mm bolts and nuts to attach to the customer supplied 98-02 Camaro LS1 engine mounts.

Mod/Coyote will use 96-04 Mustang 4.6L left & right engine mounts and will require an oil filter relocation kit. Some aftermarket accessory drives will move the alternator and create clearance issues. These mounts were designed with the Ford crate alternator bracket.

FE and Winsor use the Factory F100 engine mounts.

429/460 engines will need a rear sump oil pan.

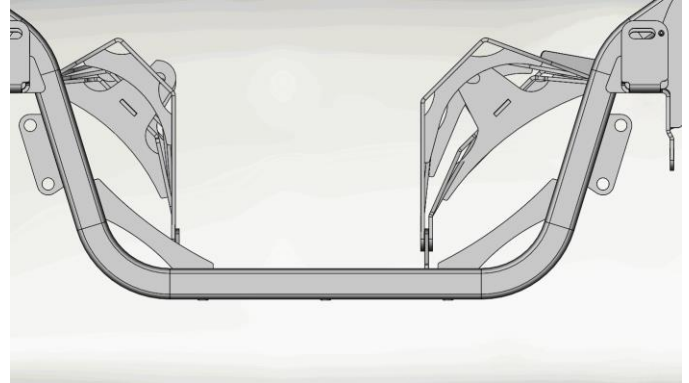

### **ENGINE MOUNT INSTALLATION:**

1. Install passenger side mount with lower connection on the outside of the mounting tab and tighten hardware to 24 lb. ft. **(Figure 1)**
2. Install drivers side mount. **WINDSOR AND FE** lower mount to be installed on the **INSIDE** of crossmember tab. **MOD/COYOTE & LS** lower mount to be installed on **OUTSIDE** of crossmember tab.
3. Torque all hardware to 24 lb-ft

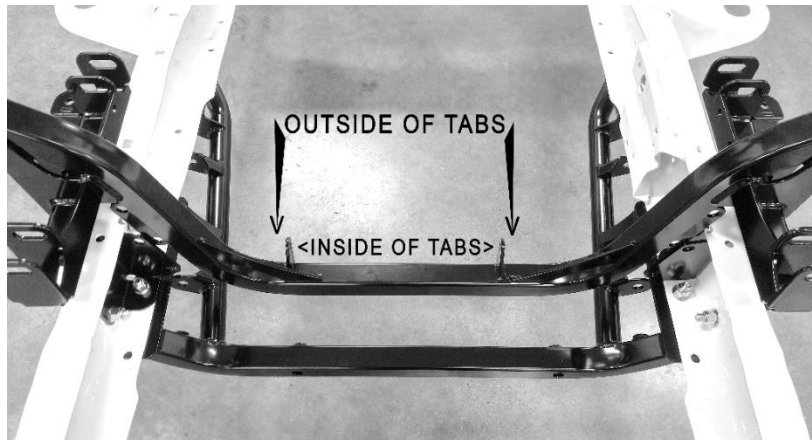

READ ALL INSTRUCTIONS CAREFULLY AND THOROUGHLY PRIOR TO STARTING INSTALLATION. PRODUCTS THAT HAVE BEEN INSTALLED ARE NOT ELIGIBLE FOR RETURN. USE THE PROPER JACKING LOCATIONS. DEATH OR SERIOUS INJURY CAN RESULT IF INSTRUCTIONS ARE NOT CORRECTLY FOLLOWED. A GOOD CHASSIS MANUAL, AVAILABLE AT YOUR LOCAL PARTS STORE, MAY ALSO AID IN YOUR INSTALLATION.

#### **• DISCLAIMER / WARRANTY •**

QA1 WARRANTS THAT THE PRODUCTS WILL BE FREE FROM DEFECTS IN MATERIAL AND WORKMANSHIP FOR ONE YEAR FROM DATE OF SALE TO THE ORIGINAL PURCHASER. QA1 MAKES NO OTHER WARRANTY OF ANY KIND, EXPRESSED OR IMPLIED. QA1 SHALL HAVE NO OBLIGATION UNDER THE FOREGOING WARRANTY WHERE THE DEFECT IS THE RESULT OF IMPROPER OR ABNORMAL USE, YOUR NEGLIGENCE, VEHICLE ACCIDENT, IMPROPER OR INCORRECT INSTALLATION OR MAINTENANCE, NOR WHEN THE PRODUCT HAS BEEN REPAIRED OR ALTERED IN ANY WAY. QA1'S LIABILITY IN THE CASE OF DEFECTIVE PRODUCTS SUBJECT TO THE FOREGOING WARRANTY SHALL BE LIMITED TO THE REPAIR OR REPLACEMENT, AT QA1'S OPTION, OF THE DEFECTIVE PRODUCTS.

THE USER UNDERSTANDS AND RECOGNIZES THAT RACING PARTS, SPECIALIZED STREET ROD EQUIPMENT, AND ALL PARTS AND SERVICES SOLD BY QA1 ARE EXPOSED TO MANY AND VARIED CONDITIONS DUE TO THE MANNER IN WHICH THEY ARE INSTALLED AND USED. QA1 SHALL BEAR NO LIABILITY FOR ANY LOSS, DAMAGE OR INJURY, EITHER TO A PERSON OR TO PROPERTY, RESULTING FROM THE INSTALLATION, DIRECT OR INDIRECT USE OF ANY QA1 PRODUCTS OR INABILITY BY THE BUYER TO DETERMINE PROPER USE OR APPLICATION OF QA1 PRODUCTS. WITH THE EXCEPTION OF THE LIMITED LIABILITY WARRANTY SET FORTH ABOVE, QA1 SHALL NOT BE LIABLE FOR ANY CLAIMS, DEMANDS, INJURIES, DAMAGES, ACTIONS, OR CAUSES OF ACTION WHATSOEVER TO BUYER ARISING OUT OF OR CONNECTED WITH THE USE OF ANY QA1 PRODUCTS. MOTORSPORTS ARE DANGEROUS; AS SUCH, NO WARRANTY OR REPRESENTATION IS MADE AS TO THE PRODUCT'S ABILITY TO PROTECT THE USER FROM INJURY OR DEATH. THE USER ASSUMES THAT RISK!